

KS3 Technology

Home learning project 2020

Lesson 1&2: Food & Nutrition

3,4&5: STEM

6&7: Textiles

DT Teachers:

Mrs Patel

Mrs Prole

Mr Hart

Miss Ledwith

Miss Jenkins

Mrs Koampah

Brief

Schools around the country regularly visit the Science Museum for school trips.

The museum would like you to design a product that the children visiting the museum would like and will help them learn more about science.

The product they would like you to design is a lunch pack with all its contents.

It must include the following:

- A healthy and nutritional lunch that children will enjoy (with 5 lunch items)
- A promotional toy or game
- A textile (fabric) keyring with lights
- A card box to hold all the items

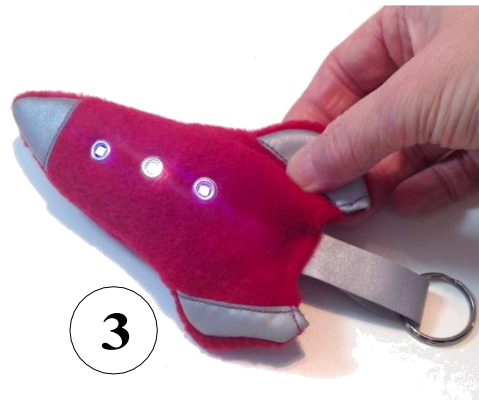

Lesson 1 & 2

Food & Nutrition:

Your task is to design a healthy and nutritional lunch that children will enjoy with five lunch items.

In order to complete this task, please complete the following steps of research:

1. Research the Eat Well Guide. Write a summary of what healthy eating is.
2. Use the British Nutrition Foundation website www.nutrition.org.uk to research the nutritional requirements for a child (go to healthy living, choose life stages on the left-hand drop-down box, you will see children towards the bottom of the page. Make summary notes of the nutritional needs of children.
3. Your task is to create a lunch menu for a vegan child. You need to explain what a vegan is and which foods they do and don't eat.
4. Produce a list of foods which would be suitable to put in your lunch box. Identify the good and bad points of each choice.
5. Now it's time to pick the 5 foods for the lunchbox; make sure it is balanced for each part of the Eat Well Guide. Explain which foods you have chosen and why you think they would be a suitable choice in a vegan lunch box.
6. Produce promotional information for the Science Museum for your lunch box.



Lesson 3,4&5

The STEM (Science, Technology, Engineering and Maths) element of this project is the designing and making of a cardboard lunch box and a game/toy.

In order to complete this task, please complete the following steps:

INVESTIGATE:

- 1) Research and investigate the task. Consider all the possible themes you could choose: such as space, chemistry, nature, physics, inventors etc.
- 2) Brainstorm the themes - sketch designs that could be linked to your themes.
- 3) Think about the two products you need to design.

LUNCHBOX:

What does the lunchbox need to do - consider the user and the museum selling it? What information is needed on the outside?

How will it promote the Science Museum?

TOY/GAME:

How will it promote the Science Museum? How will it work?

How will it entertain the child?

- 4) Consider the designs of the toy/game:

Could it be something the child builds?

Could it be something that they can play with straight away?

What will it teach them about science?

DESIGN

- 5) Come up with 3 designs for both the toy/game (on paper or try and make a model of it) and the lunchbox (see sheet)

MAKE

- 6) Use the internet to draw out and make your design (outline of the lunchbox on the following pages).

EVALUATE

- 7) Ask people at home to evaluate your designs. What do they like about your designs? What would they change about them? Then consider their comments - can you make any improvements?

DESIGN

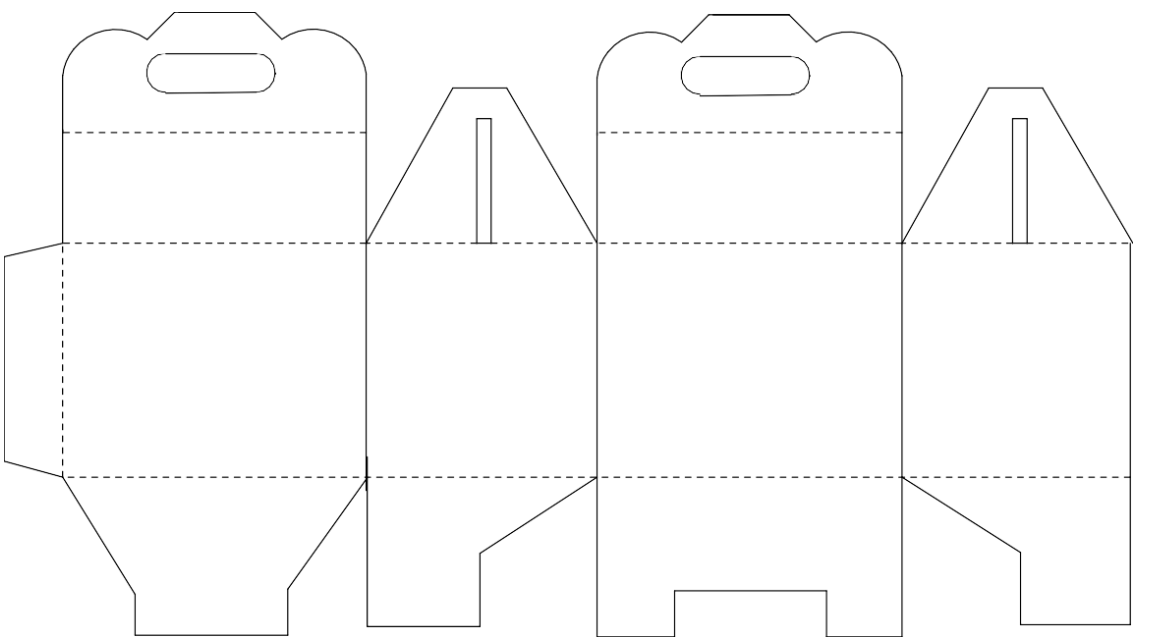
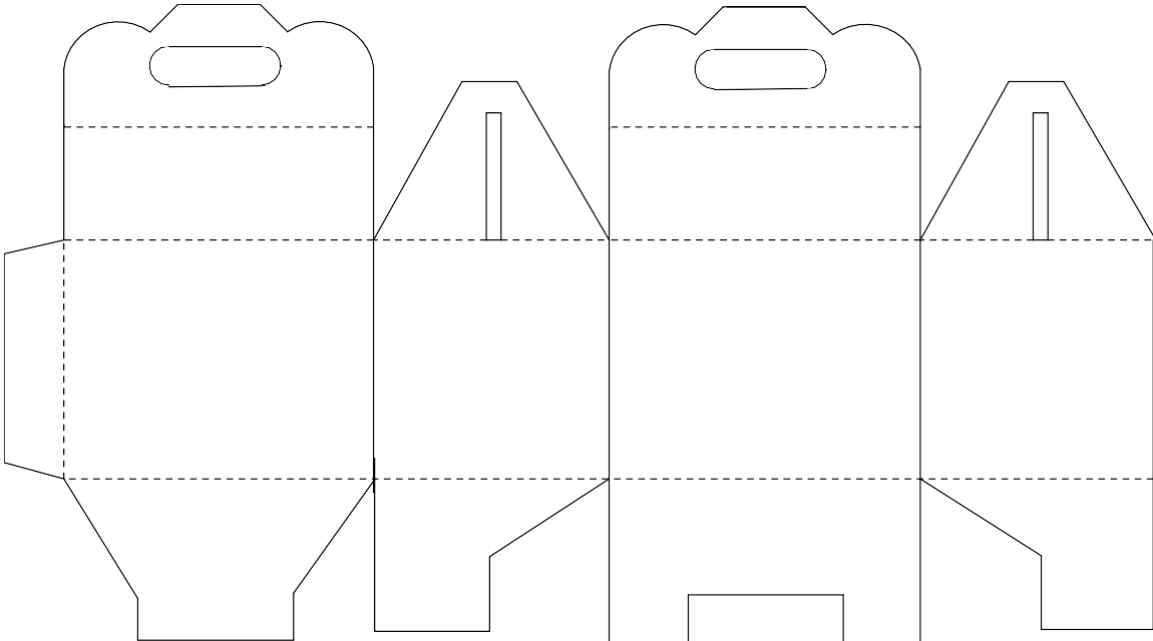
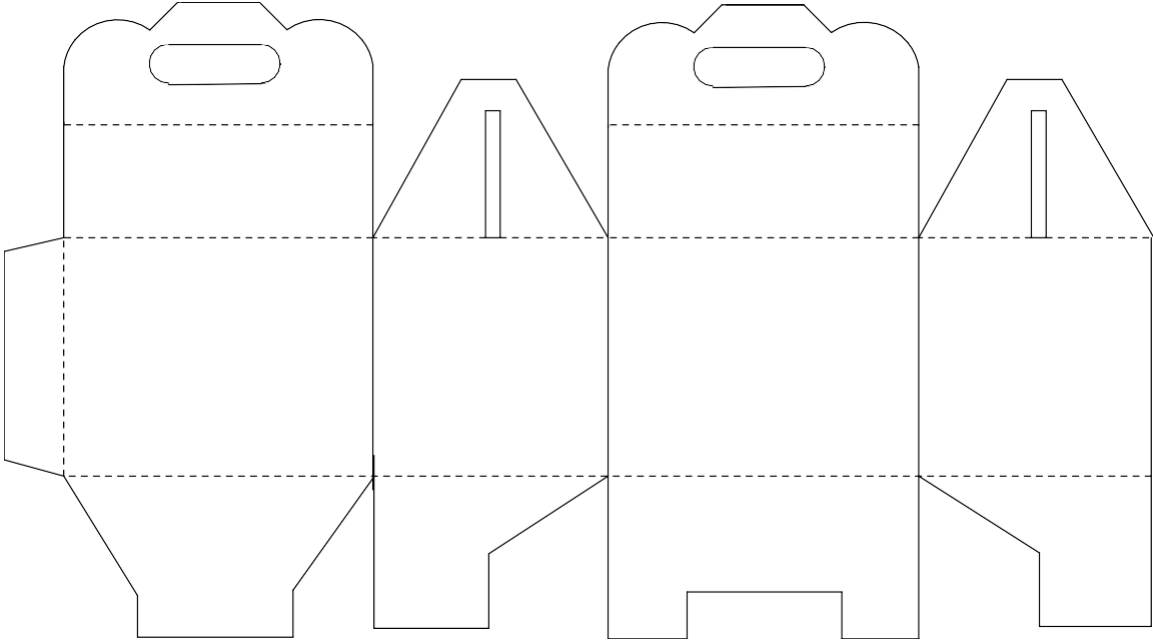

**SCIENCE
MUSEUM**

Make

Use the net
(paper outline)
to make your
lunchbox

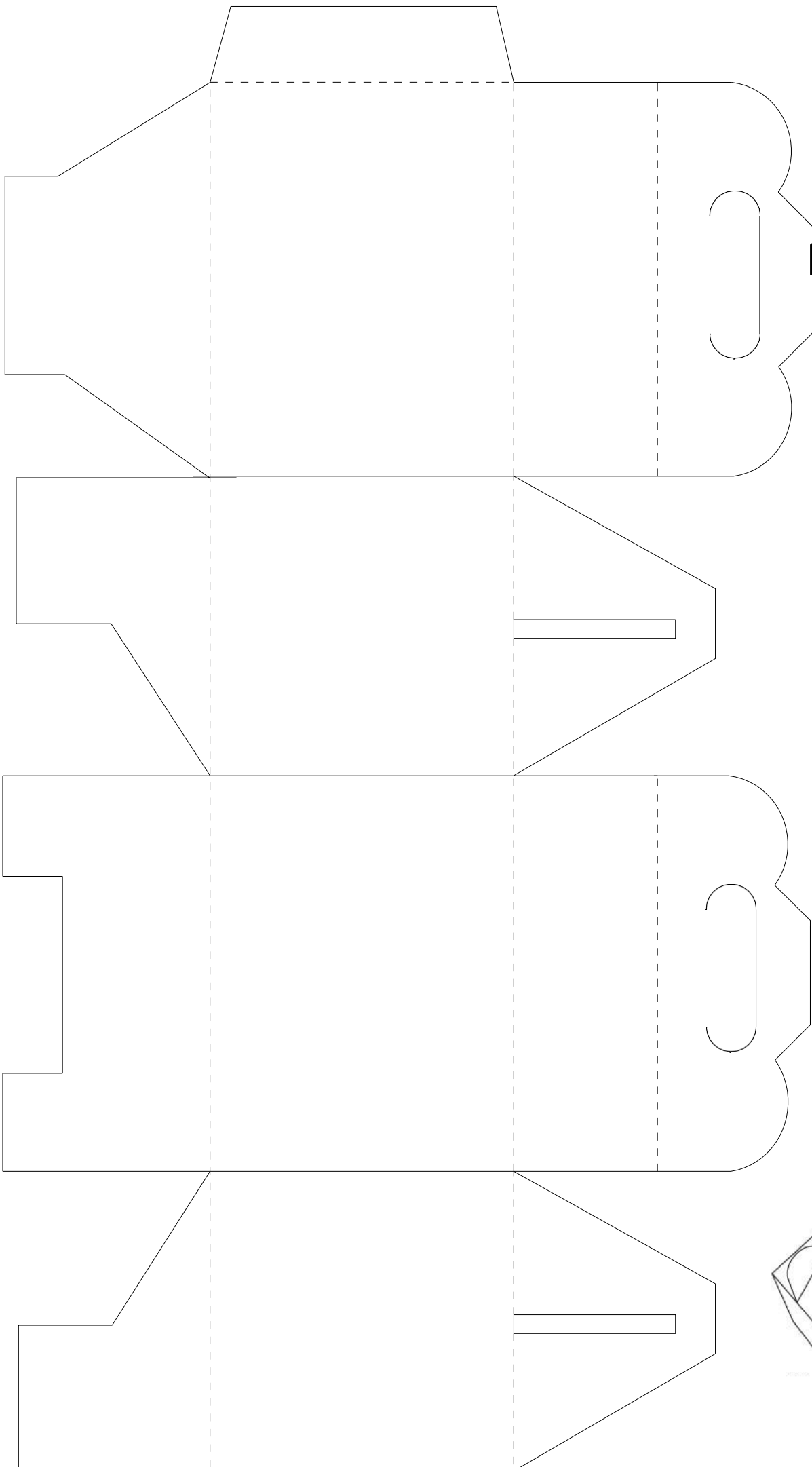

Lesson 6&7

The Textiles element is the designing of a fabric keyring with lights.

In order to complete this task, please complete the following steps:

INVESTIGATE

- Research and investigate the task. Consider themes: such as space, chemistry, nature, physics, inventors etc.
- Brainstorm themes - consider designs that could be linked to your themes.
- Think about what the product needs to do

How will it promote the Science Museum?

How will it work? Consider the switch and the keyring attachment

How will it light up?

Could it entertain the child?

- Consider the designs of the keyring

Could it be embroidered? Could it have an extra function such as purse or earphone holder?

Could it teach them about science?

DESIGN

- Come up with 3 designs for the keyring

MAKE

- Sketch your keyring design showing the front, back, any extra details or functions.

EXTENSION: Try and draw out the pattern to cut the fabric.

EVALUATE

Ask people at home to evaluate your designs.

What do they like about your designs?

What would they change about them?

Then consider their comments - can you make any improvements?

Notes pages:

