

Dear Parents/Carers,

I am delighted to be able to write to you in what feels like a more 'normal' time for our students and staff. The impact of Covid-19 as we know has been significant on everyone but none more so than the students. One of the areas affected the most has been student attendance with the national average reducing from 94% to 85%. I am pleased to report at KSS that student attendance has rocketed in the last few weeks and Mrs Hume the attendance manager reports daily with the remarkable improvements being made.

The House system launched by Mrs Castrey in the last half term has started to make an impact with all individual student achievements being added to the collective House team totals. We are planning some exciting rewards for the leading Houses over the next few weeks.

The school was delighted to be a feature on BBC Radio Stoke during the 18th of February John Acres breakfast show, as Mark Bright spoke about his affinity to the school and his delight at being voted to represent one of the school houses. You can find a recording of Marks interview @ [John Acres - 18/02/2022 - BBC Sounds](#) from around the 1:16 mark on the episode timeline.

In other news, the students are consistently achieving remarkable things. The Year 11's are fully engaged in a second mock examination window, the Year 10's have made dramatic improvements in attitude and growth mindset and we are looking forward to celebrating this at the parents evening later this month. The Year 9 students have started to show accelerated progress and the options process will be taking place for this cohort after the Easter holidays.

The Year 8 students have been reorganised into new teaching groups which is seeing better behaviours and engagement levels, whilst the fantastic Year 7 group have continued to shine.

Over the next few weeks we will also be visited by Year 5 students from our local primary schools. This is designed to build greater links with future KSS students and support KS2 students in their transition to secondary school. Watch this space for updates on Facebook and in future Headteacher bulletins.

Finally, a thank you to parents/carers for your continued support. It isn't ideal at the moment with the restricted access to Gloucester Road and the impact that this is having on the local area but punctuality to school has improved after an alarming dip in January. It is an important life skill to be on time at the start of the day so we thank you for your support with this and with all aspects of our 'Code of Conduct'.

Yours faithfully

Mr S Frost



- 17.3.22 Anti-Bullying/Safeguarding Student Council Meeting
- 31.3.22 Year 10 Parents Evening
- 31.3.22 Year 11 Mock Results Day



#DigitalByDesign



Headteacher Bulletin

Curriculum Feedback to Parents/Carers...

An area for development that was raised in a recent parental survey, was that you would like to know more about what your child is studying in each of their subjects.

As a result of this feedback, the staff at KSS have created a new way of presenting the curriculum content for each subject that is visual and eye catching. Over the next few Headteacher bulletins I will be sharing with you curriculum maps from a variety of subjects.

Below is the KS3 Spanish Curriculum Map from Mrs Raybould.

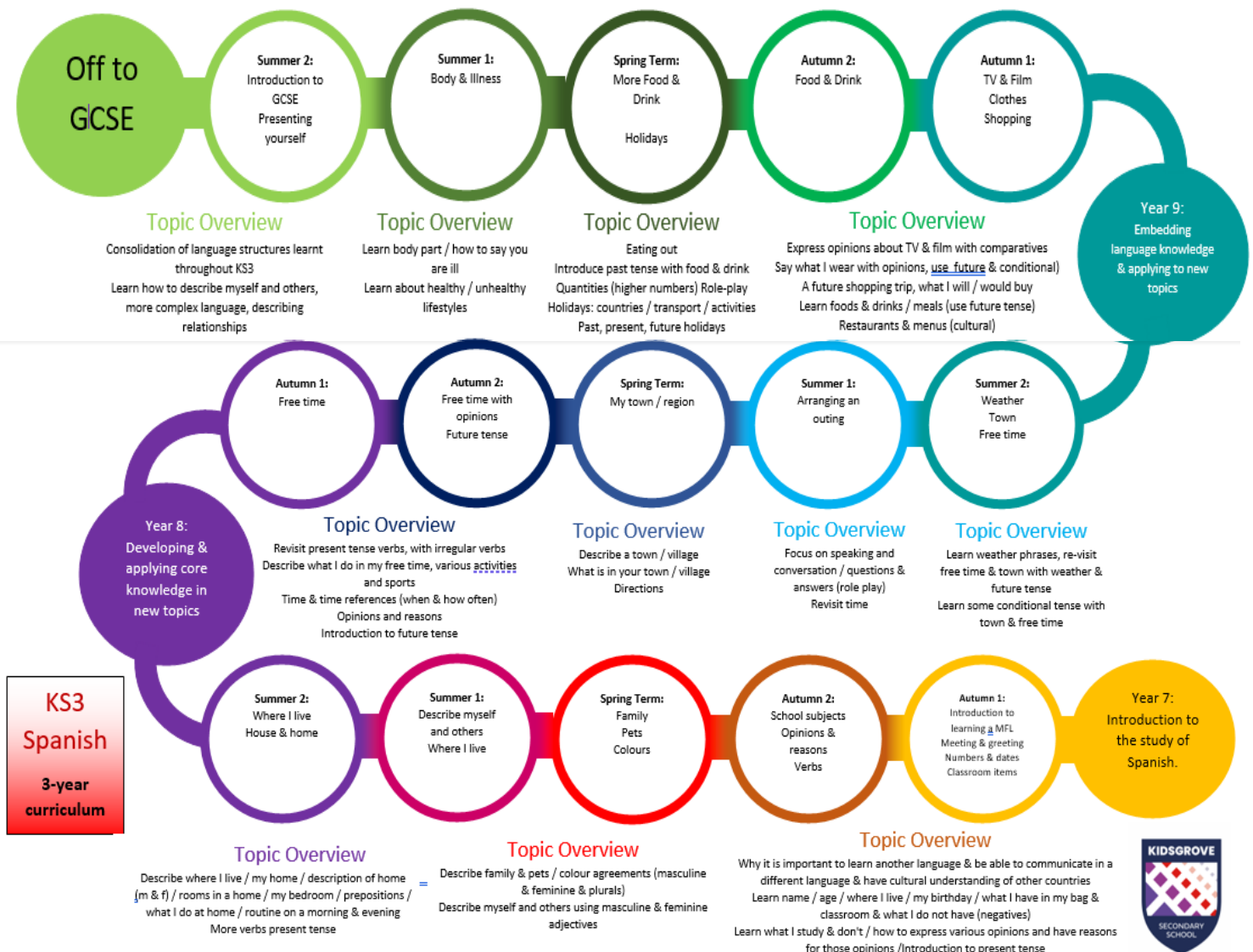

#DigitalByDesign



Headteacher Bulletin

A message from Mr Old...

We celebrated 'World Book Day' with various events throughout the day last Thursday with students participating in quizzes, Kahoot's and recommended reading. Staff also put forward passages from their favourite books.

In KS3, students wrote a twisted tale with the opportunity to have their work published in a book compiled of the best 250 word stories or 'mini-sagas'.

Geography lessons were dedicated to the book 'Survivors' by David Long. A selection of short notices where ordinary people have been thrust into unusual and scary fights for survival. The stories focused upon the Amazon Rainforest!

A big thank you to students, Mrs Castrey and Mrs Weaver for all of their efforts.

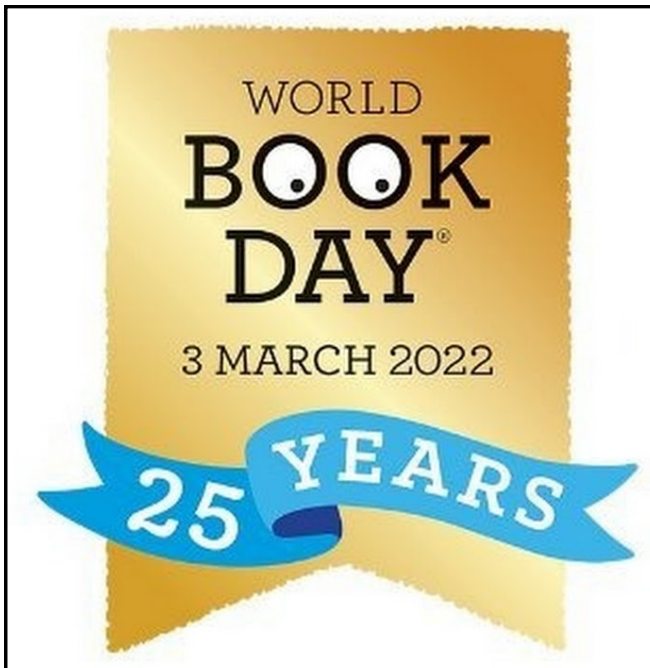
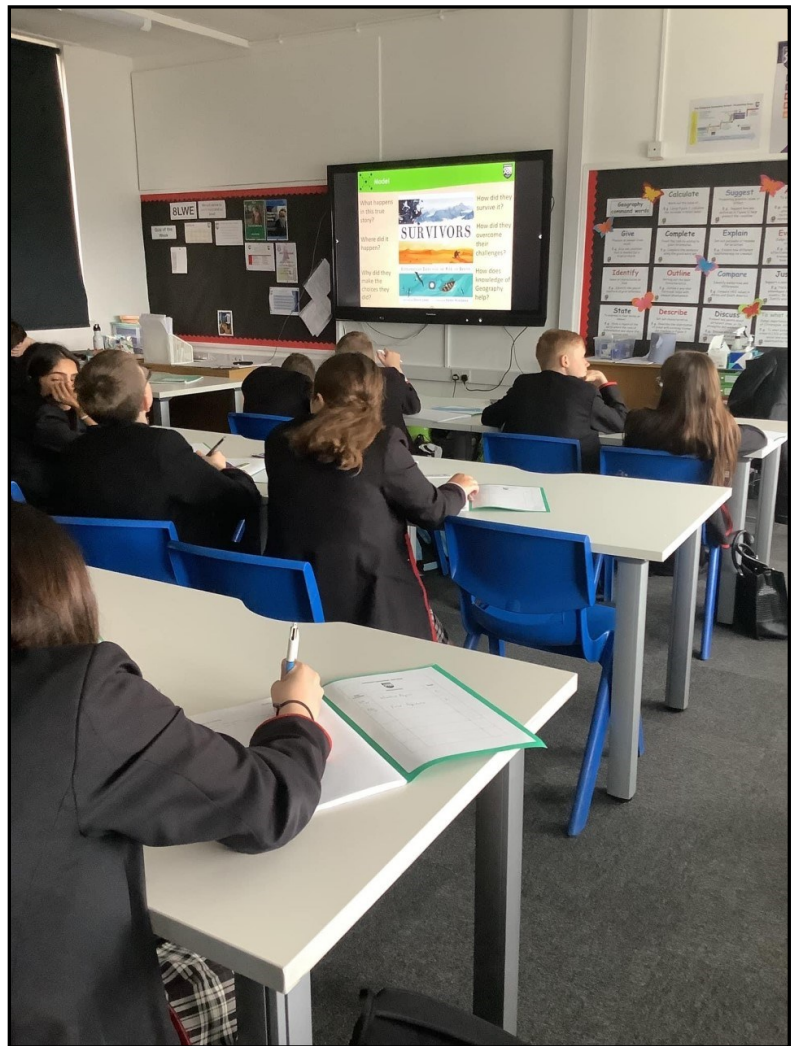

#DigitalByDesign



Kidsgrove
Learning Campus
INSPIRE INNOVATE CREATE



Shaw
Education
Trust

Headteacher Bulletin

A message from Mrs Castrey...

To show our support for the people of Ukraine, staff and students will be asked to donate £1, payable by 'Parent Pay' to support the British Red Cross and their efforts to help people caught up in the crisis.

More information can be found at the website link below:

[DEC Ukraine Humanitarian Appeal | British Red Cross](#)

The donations raised by KSS will be used for the following:

Provide food, first aid and clear water

Support hospital and healthcare

Helping families to stay in contact with each other

Helping to repair homes, schools and community centres



A message from Ms Critchlow...

'TinkerCad' is a free online CAD software which has allowed the Year 10 students to put their desk tidy designs into CAD.

The students spent around four lessons on this section working on the starter tasks which allows the students to have a go at the functions available on the software.

The designs belong to Keira, Ashleigh, Kaitlyn and Amelia.

They are now moving onto one of the final stages of the project and beginning to make their physical designs in the workshop.

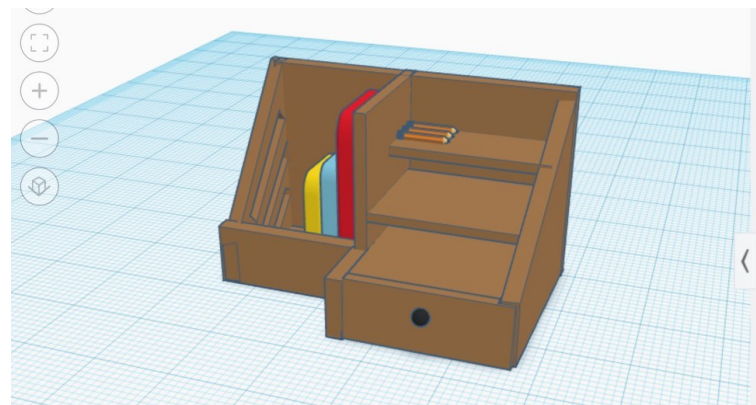
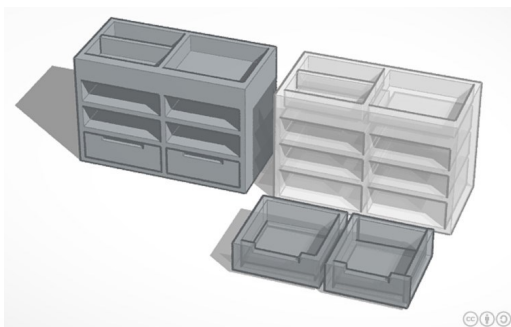
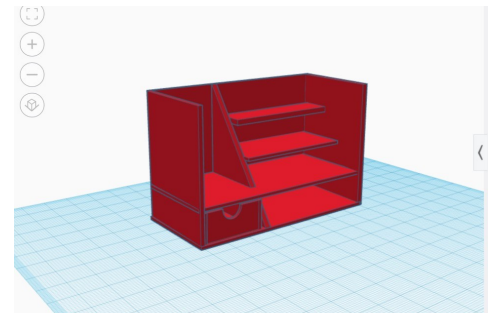
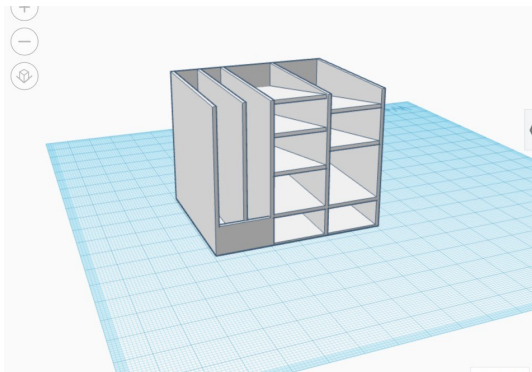

#DigitalByDesign



Kidsgrove
Learning Campus
INSPIRE INNOVATE CREATE



Shaw
Education
Trust

House Update...

The House system as mentioned on the opening page is starting to take shape with competitions in PE and other curriculum areas. This academic year we have had a huge push on achievement points as we have changed the culture in the school to maximise the celebration of student successes. There have been over **90,000 achievement points** issued to students for excellence this year so far which is a huge increase on the last academic year and we still a long way to go before the summer holiday.

These achievement points have been collated and allocated to the Houses retrospectively and up to the 11.3.22 the league table is shown below with Wedgewood leading the way with over **24000 points**. I am confident the other houses will step up and make it an interesting final term.

TOTAL HOUSE POINTS

