

Forming & Solving Equations

A collection of 9-1 Maths GCSE Sample and Specimen questions from AQA, OCR, Pearson-Edexcel and WJEC Eduqas.

Name:	
Total Marks:	

1. Kieran, Jermaine and Chris play football.

- Kieran has scored 8 more goals than Chris.
- Jermaine has scored 5 more goals than Kieran.
- Altogether they have scored 72 goals.

How many goals did they each score?

Kieran

Jermaine

Chris

[5]

2. In this row of boxes, you start with 5 and 7.

5	7			
---	---	--	--	--

You add 5 and 7 to get 12 to go in the third box.

You add 7 and 12 to get 19 to go in the fourth box.

You add 12 and 19 to get 31 to go in the fifth box.

5	7	12	19	31
---	---	----	----	----

Complete these rows of boxes using the rule shown above.

(a)

4	6			
---	---	--	--	--

[1]

(b)

			34	55
--	--	--	----	----

[2]

(c) Complete this row of boxes, writing your expressions in their simplest form.

a	b			
-----	-----	--	--	--

[2]

(d) Use your answer to (c) to help you fill in the missing numbers in this row of boxes.

6				57
---	--	--	--	----

[3]

3. The perimeter of the triangle is the same length as the perimeter of the square.

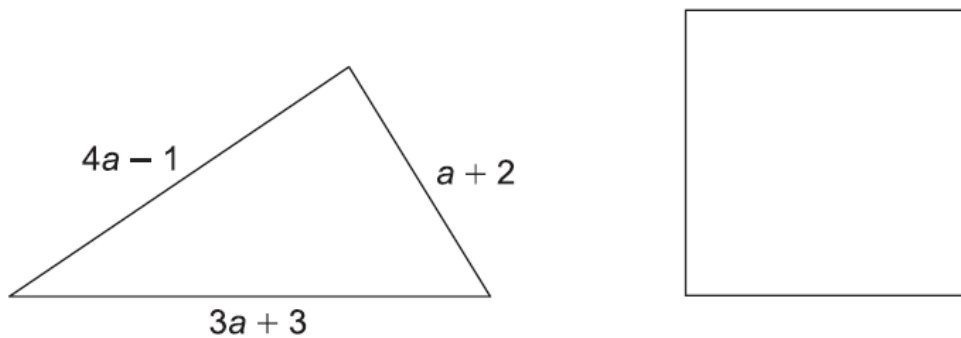

Find an expression for the length of one side of the square in terms of a .

Give your answer in its simplest form.

..... [4]

4. Here is a pentagon.

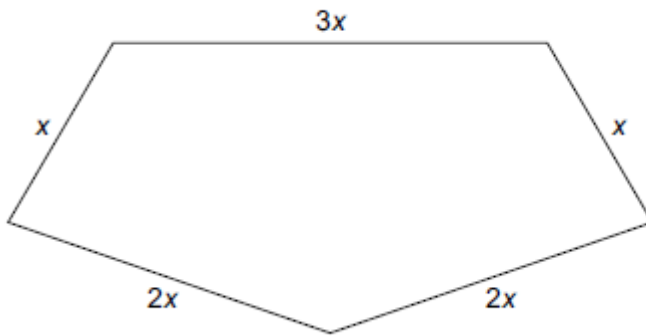

Not to scale

Write down an expression for the perimeter of the pentagon.

Give your answer in its simplest form.

..... [1]

5. Shape A is a rectangle of length x cm and width 2 cm.

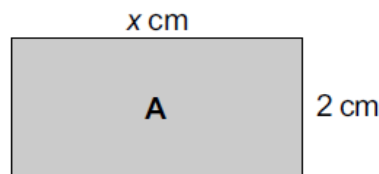

Not to scale

The shape below contains two rectangles that are identical to shape A.

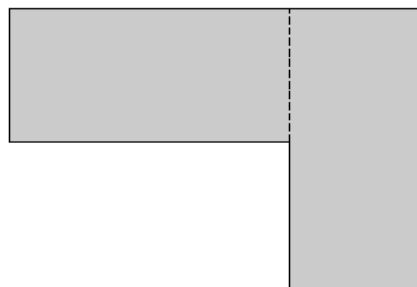

Not to scale

Work out an expression for the perimeter of this shape.

Give your answer in its simplest form.

..... cm [3]

6. This is a square.

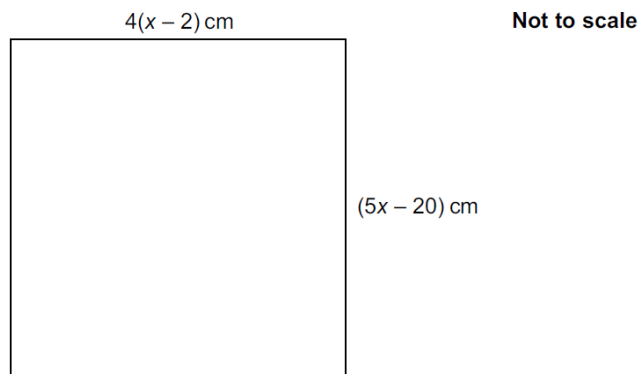

Work out the length of the side of the square.

..... cm [5]

7. ABCH is a square.

HCFG is a rectangle.

CDEF is a square.

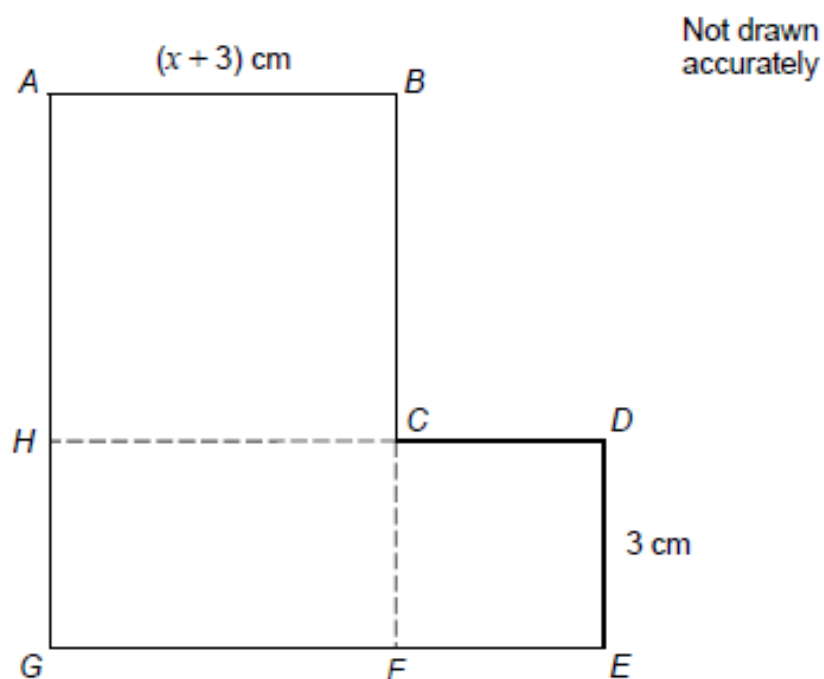

They are joined to make an L-shape.

Show that the total area of the L-shape, in cm^2 , is $x^2 + 9x + 27$

[4]

8. Here is a parallelogram.

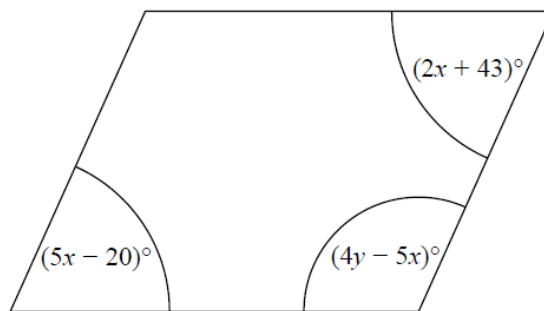

Work out the value of x and the value of y .

$x = \dots\dots\dots$

$y = \dots\dots\dots$

[5]

9. Rob buys p packets of plain crisps and c packets of cheese crisps.

Write down an expression for the total number of packets of crisps Rob buys.

$\dots\dots\dots$

[1]

10. Here is a rectangle made of card.

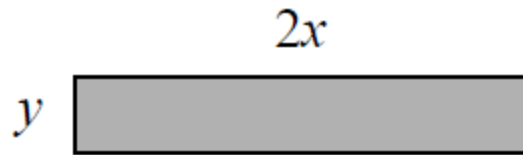

The measurements in the diagram are in centimetres.
Lily fits four of these rectangles together to make a frame.



The perimeter of the inside of the frame is P cm.

(a) Show that $P = 8x - 4y$

[2]

Magda says,

"When x and y are whole numbers, P is always a multiple of 4."

(b) Is Magda correct?

You must give a reason for your answer.

.....
.....[2]

11. Dimitar has 20 sweets.
Pip also has 20 sweets.
Dimitar gives Pip x sweets.
Dimitar then eats 5 of his sweets.
Pip then eats half of her sweets.

Write expressions for the number of sweets Dimitar and Pip now have.

Dimitar Pip [3]

12. You can use this rule to work out the total cost, in pounds, of hiring a carpet cleaner.

Multiply the number of days by 7.8 and then add 12

Andy hires a carpet cleaner.

The total cost is £82.20

- (a) Work out the number of days Andy hires the carpet cleaner for.

.....days [2]

Chloe hires a carpet cleaner for y days.

The total cost is £ T .

- (b) Write down a formula for T in terms of y .

..... [2]

13. In the diagram all measurements are in centimetres.

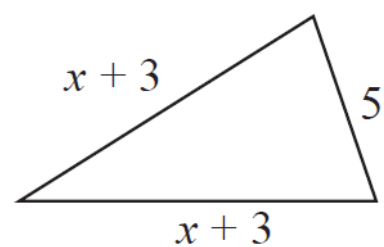
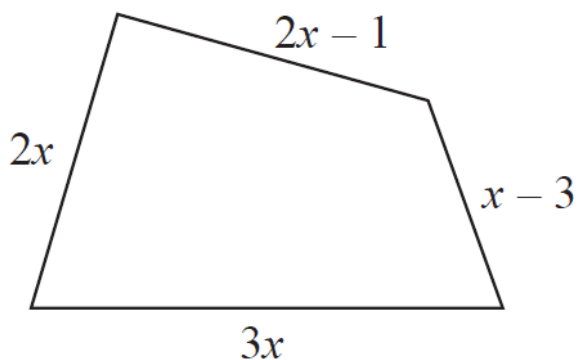

The perimeter of the quadrilateral is twice the perimeter of the triangle.

Work out the perimeter of the quadrilateral.

..... cm [4]

14. Write an expression for the total cost, in pounds, of
 x jumpers at £15 each
 and
 y shirts at £12 each.

[1]

15. Three boxes contain counters.

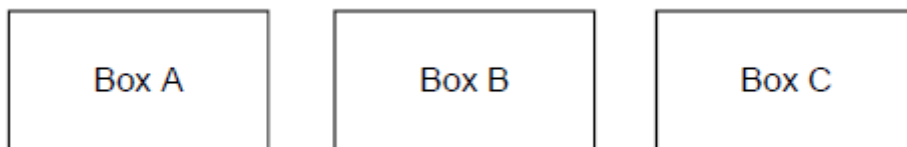

There are 62 counters in total.

The total number of counters in box A and box B is 34

The difference between the number of counters in box A and box C is 9

Work out the number of counters in each box.

Box A _____ Box B _____ Box C _____ [3]

16. A shape is made from rectangles.

- (a) On the diagram below shade an area represented by the expression ab

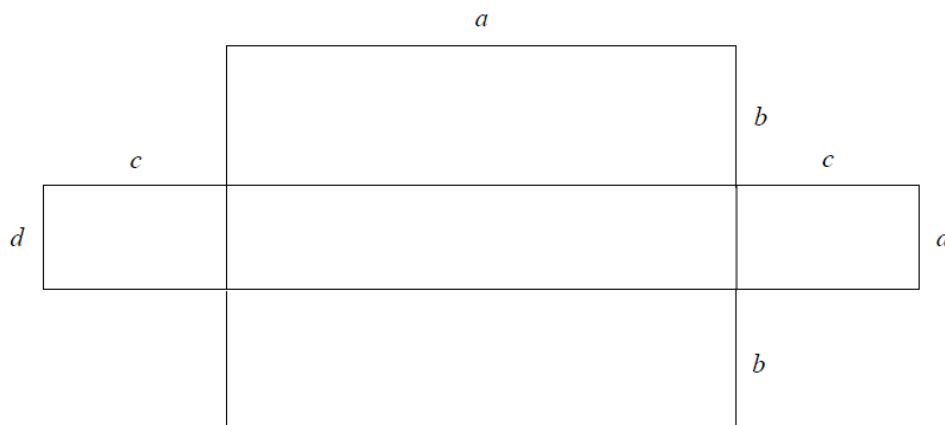

[1]

(b) On the diagram below shade an area represented by the expression $ad + cd$

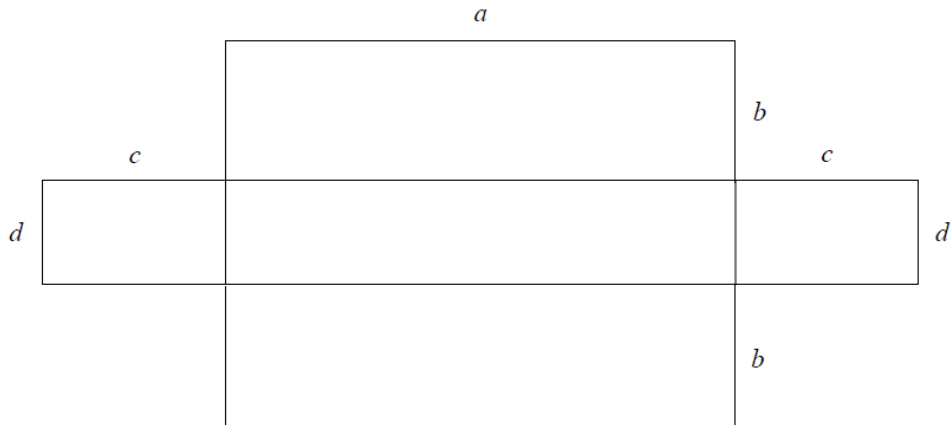

[1]

(c) On the diagram below shade the area represented by the expression $d(a + 2c)$

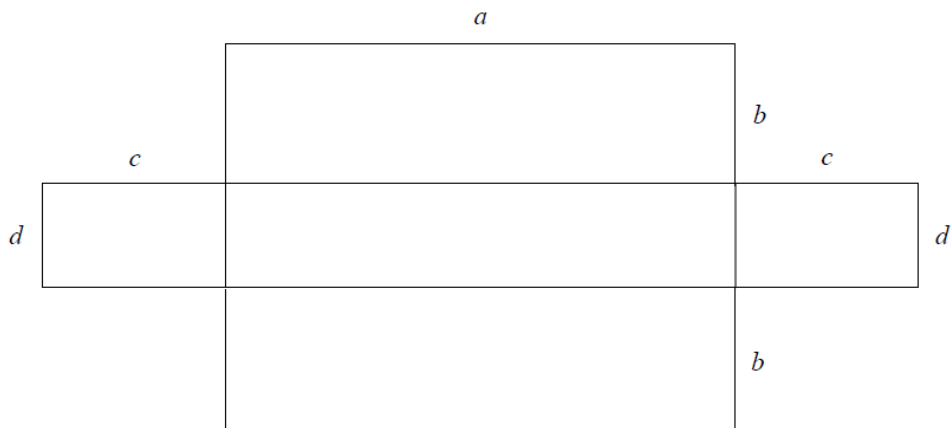

[1]

(d) Write down an expression for the area of the whole shape.

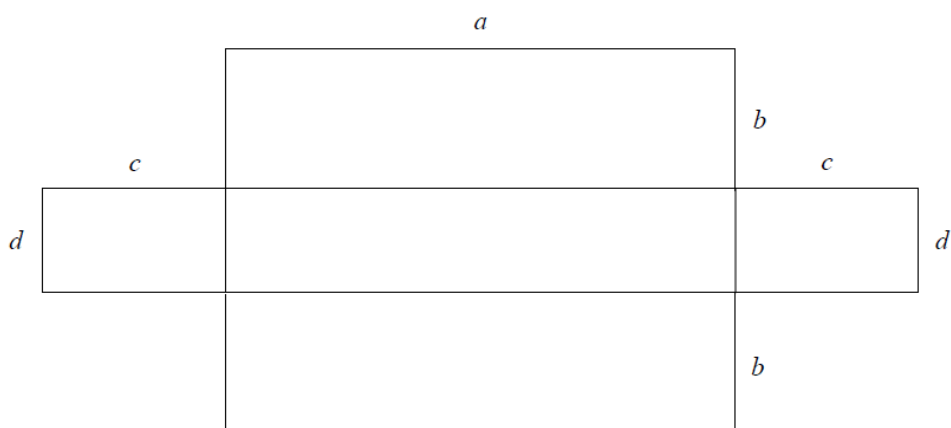

[1]

17. Three straight lines are shown.

Work out the value of x .

Not drawn accurately

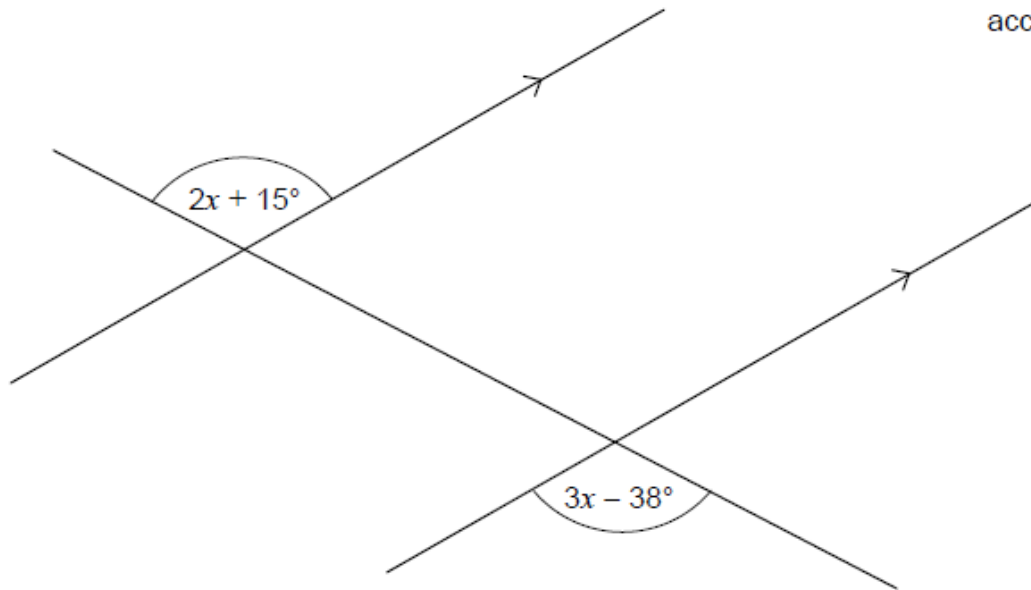

[3]

18. Which of these can be written as $\frac{a}{b}$?

Circle your answer.

$b \div a$

$a - b$

$a \div b$

$b - a$

[1]

19. The diagram shows a square.

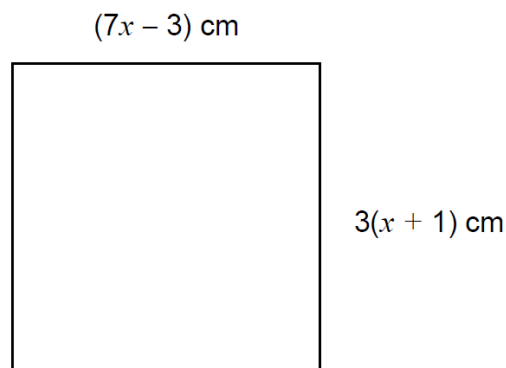

Work out the length of one side of the square.

[4]

20. Each diagram represents a balance with the total weight on each side being equal.

Find the values of A, B and C.

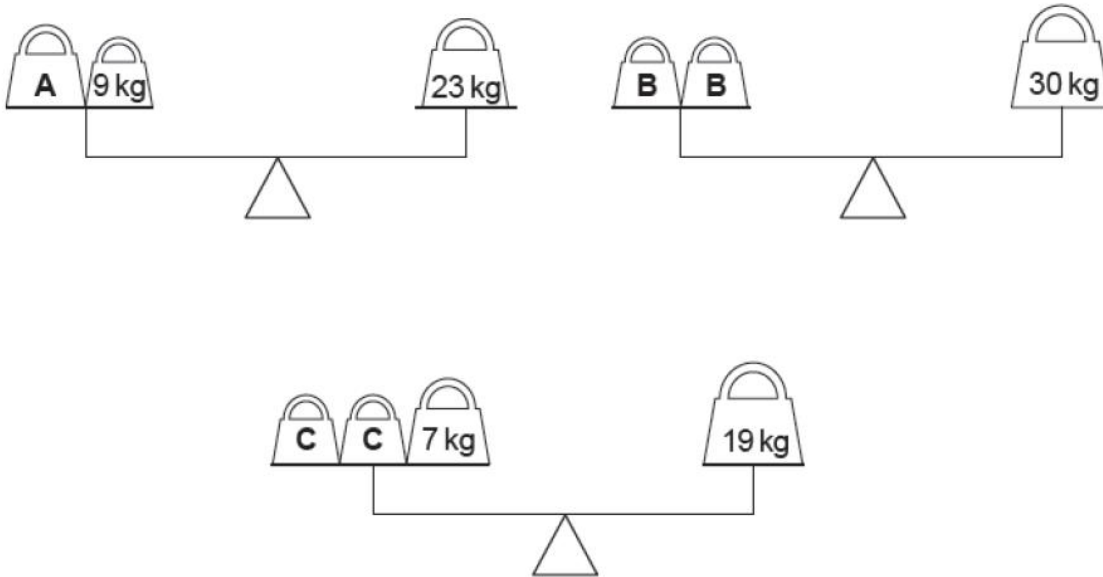

A =kg B =kg C =kg [3]

21. Charlie has x pens.

Lisa has 3 more pens than Charlie.

Julian has twice as many pens as Lisa.

How many pens do Charlie, Lisa and Julian have altogether?

Simplify your answer as far as possible.

[4]

22. The diagram shows a square.

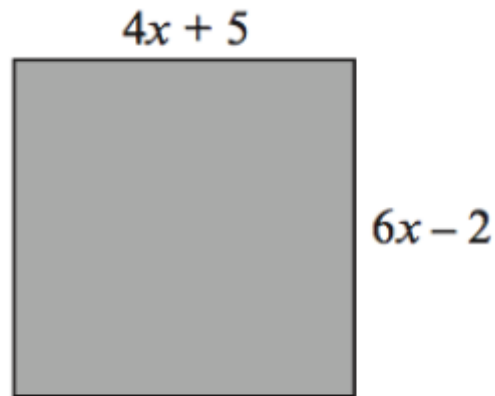

Diagram not drawn to scale

All the lengths are measured in centimetres.

Diagram not drawn to scale

Use an algebraic method to find the length of one side of the square.

[5]

23. The diagram shows a right-angled triangle.



All the angles are in degrees.

Work out the size of the smallest angle of the triangle.

[3]

24. ABCD is a trapezium.

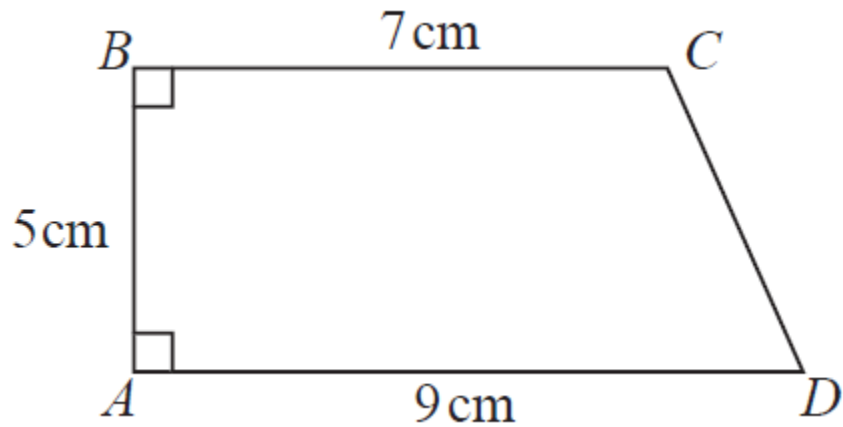

A square has the same perimeter as this trapezium.

Work out the area of the square.

Give your answer correct to 3 significant figures.

..... cm² [5]

CREDITS AND NOTES

Question	Awarding Body	Question	Awarding Body
1	OCR	13	Pearson Edexcel
2	OCR	14	AQA
3	OCR	15	AQA
4	OCR	16	AQA
5	OCR	17	AQA
6	OCR	18	AQA
7	AQA	19	AQA
8	Pearson Edexcel	20	WJEC Eduqas
9	Pearson Edexcel	21	WJEC Eduqas
10	Pearson Edexcel	22	WJEC Eduqas
11	Pearson Edexcel	23	Pearson Edexcel
12	Pearson Edexcel	24	Pearson Edexcel

Notes:

These questions have been retyped from the original sample/specimen assessment materials and whilst every effort has been made to ensure there are no errors, any that do appear are mine and not the exam board s (similarly any errors I have corrected from the originals are also my corrections and not theirs!).

Please also note that the layout in terms of fonts, answer lines and space given to each question does not reflect the actual papers to save space.

These questions have been collated by me as the basis for a GCSE working party set up by the GLOW maths hub - if you want to get involved please get in touch. The objective is to provide support to fellow teachers and to give you a flavour of how different topics "could" be examined. They should not be used to form a decision as to which board to use. There is no guarantee that a topic will or won't appear in the "live" papers from a specific exam board or that examination of a topic will be as shown in these questions.



Links:

AQA <http://www.aqa.org.uk/subjects/mathematics/gcse/mathematics-8300>

OCR <http://ocr.org.uk/gcsemaths>

Pearson Edexcel <http://qualifications.pearson.com/en/qualifications/edexcel-gcses/mathematics-2015.html>

WJEC Eduqas <http://www.eduqas.co.uk/qualifications/mathematics/gcse/>

Contents:

This version contains questions from:

AQA – Sample Assessment Material and Practice set 1

OCR – Sample Assessment Material and Practice set 1

Pearson Edexcel – Sample Assessment Material, Specimen set 1 and Specimen set 2.

WJEC Eduqas – Sample Assessment Material