

# Volume of Prisms, Cones, Pyramids & Spheres

A collection of 9-1 Maths GCSE Sample and Specimen questions from AQA, OCR, Pearson-Edexcel and WJEC Eduqas.

|              |  |
|--------------|--|
| Name:        |  |
| Total Marks: |  |

1. Jo makes a pendant by cutting two semicircles of radius 1 cm from the rectangle, as shown below.

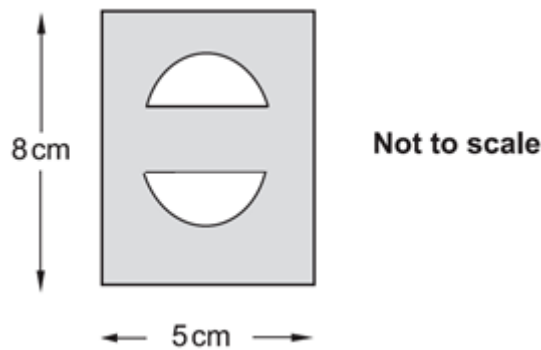

Show that the shaded area is  $36.9 \text{ cm}^2$  correct to three significant figures.

[4]

The silver Jo uses is 2 mm thick.

Find the volume of silver in the pendant.

Give your answer in  $\text{cm}^3$ .

.....  $\text{cm}^3$  [3]

2. Four solid balls are packed in a cylindrical container.

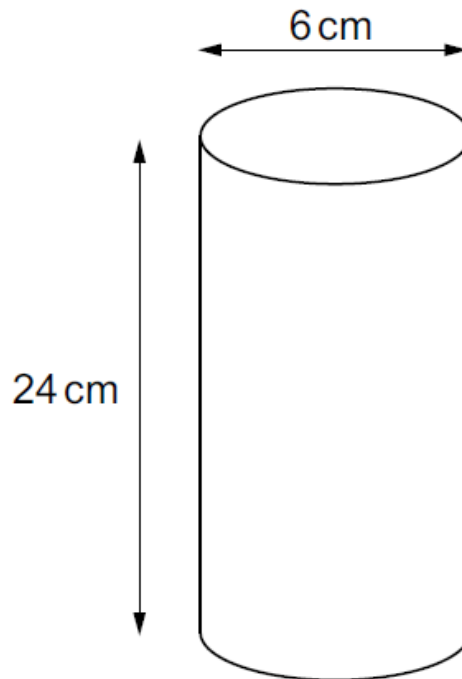

The diameter of each ball is 6 cm.

The cylinder has diameter 6 cm and height 24 cm.

Calculate the volume of unused space in the cylinder.

(The volume  $V$  of a sphere is  $V = \frac{4}{3}\pi r^3$  )

..... cm<sup>3</sup> [6]

3. The diagram shows a tank in the shape of a cuboid.

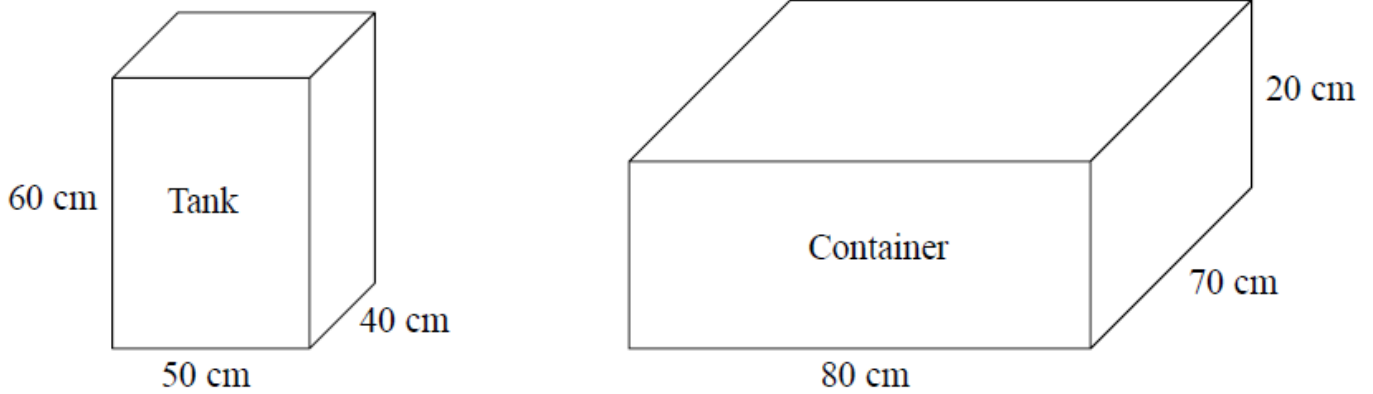

It also shows a container in the shape of a cuboid.

The tank is full of oil.

The container is empty.

35% of the oil from the tank is spilled.

The rest of the oil from the tank is put into the container.

Work out the height of the oil in the container.

Give your answer to an appropriate degree of accuracy.

..... cm [5]

4. The diagram shows an oil tank in the shape of a prism.

The cross section of the prism is a trapezium.

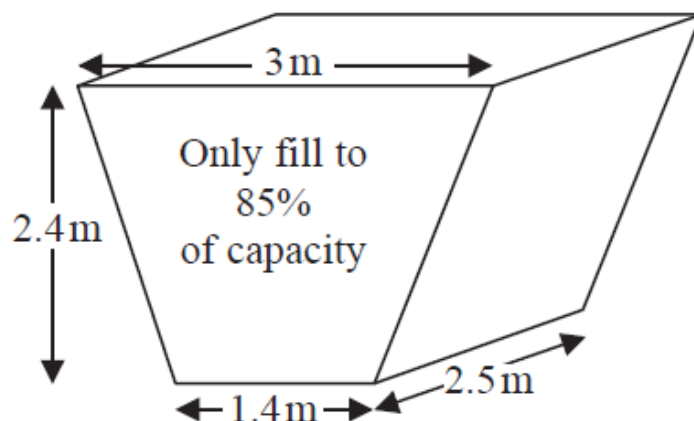

The tank is empty.

Oil flows into the tank.

After one minute there are 300 litres of oil in the tank.

Assume that oil continues to flow into the tank at this rate.

(a) Work out how many more minutes it takes for the tank to be 85% full of oil.

(1 m<sup>3</sup> = 1000 litres)

..... minutes [5]

The assumption about the rate of flow of the oil could be wrong.

(b) Explain how this could affect your answer to part (a).

[1]

5. This pyramid has a square base.

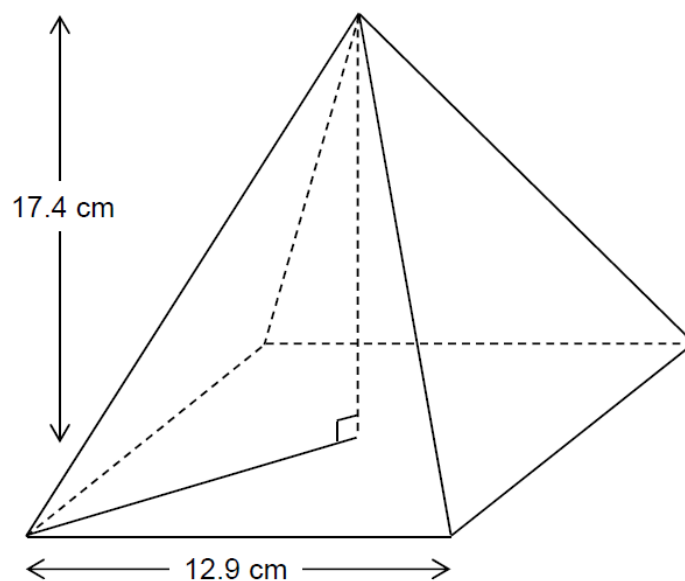

Volume of a pyramid =  $\frac{1}{3} \times$  area of base  $\times$  perpendicular height

Work out the volume of the pyramid.

[3]

6. A cube has edges of length 0.8 metres.

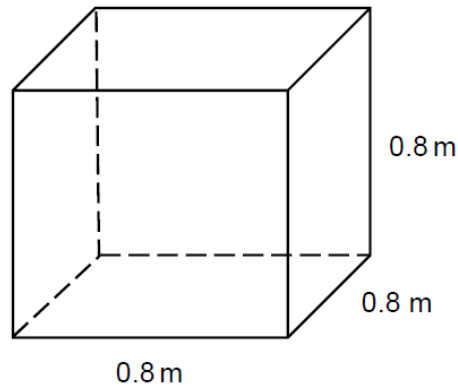

Work out its volume in cubic centimetres.

\_\_\_\_\_ cm<sup>3</sup> [2]

7. A water tank is a cylinder with radius 40 cm and depth 150 cm

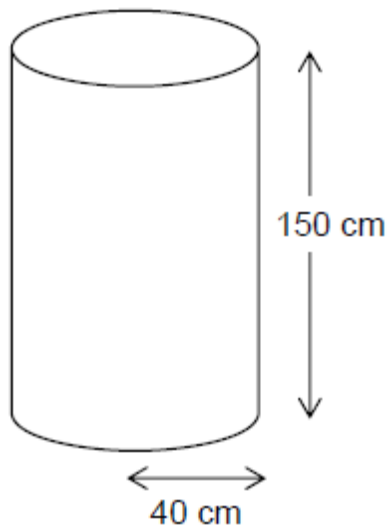

It is filled at the rate of 0.2 litres per second.

1 litre = 1000 cm<sup>3</sup>

Does it take longer than 1 hour to fill the tank?

You must show your working.

[4]

8. A cuboid with length 45 cm, width 20 cm and height 35 cm is completely filled with water.

The water is then poured into a larger cuboid with length 100 cm and width 15 cm. Calculate the height of the water in the larger cuboid.

Show all your working.

[4]

9. The diagram shows a sand pit.

The sand pit is in the shape of a cuboid.

Sally wants to fill the sand pit with sand.

A bag of sand costs £2.50

There are 8 litres of sand in each bag.

Sally says,

*"The sand will cost less than £70"*

Show that Sally is wrong.

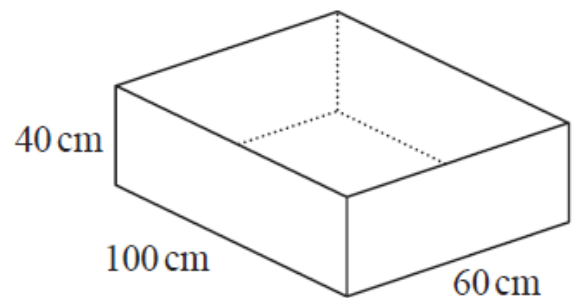

[5]

## CREDITS AND NOTES

| Question | Awarding Body   |
|----------|-----------------|
| 1        | OCR             |
| 2        | OCR             |
| 3        | Pearson Edexcel |
| 4        | Pearson Edexcel |
| 5        | AQA             |
| 6        | AQA             |
| 7        | AQA             |
| 8        | WJEC Eduqas     |

### Notes:

These questions have been retyped from the original sample/specimen assessment materials and whilst every effort has been made to ensure there are no errors, any that do appear are mine and not the exam board s (similarly any errors I have corrected from the originals are also my corrections and not theirs!).

Please also note that the layout in terms of fonts, answer lines and space given to each question does not reflect the actual papers to save space.

These questions have been collated by me as the basis for a GCSE working party set up by the GLOW maths hub - if you want to get involved please get in touch. The objective is to provide support to fellow teachers and to give you a flavour of how different topics "could" be examined. They should not be used to form a decision as to which board to use. There is no guarantee that a topic will or won't appear in the "live" papers from a specific exam board or that examination of a topic will be as shown in these questions.

### Links:

AQA <http://www.aqa.org.uk/subjects/mathematics/gcse/mathematics-8300>

OCR <http://ocr.org.uk/gcsemaths>

Pearson Edexcel <http://qualifications.pearson.com/en/qualifications/edexcel-gcses/mathematics-2015.html>

WJEC Eduqas <http://www.eduqas.co.uk/qualifications/mathematics/gcse/>

### Contents:

This version contains questions from:

AQA – Sample Assessment Material and Practice set 1

OCR – Sample Assessment Material and Practice set 1

Pearson Edexcel – Sample Assessment Material, Specimen set 1 and Specimen set 2.

WJEC Eduqas – Sample Assessment Material

