

Stage 3 PROMPT sheet

3/1 Count in multiples

Now you must learn these multiples

Multiples of 4	Multiples of 8	Multiples of 50	Multiples of 100
0	0	0	0
4	8	50	100
8	16	100	200
12	24	150	300
16	32	200	400
20	40	250	500
24	48	300	600
28	56	350	700
32	64	400	800
36	72	450	900
40	80	500	1000

hundreds	tens	units
3	5	2

- To find 10 more or 10 less, it is the 'tens digit' that changes
10 more than 352 becomes 362
10 less than 352 becomes 342

hundreds	tens	units
3	5	2

- To find 100 more or 100 less, it is the 'hundreds' digit that changes
100 more than 352 becomes 452
100 less than 352 becomes 252

3/2 Recognise place value

hundreds	tens	units
3	5	2

352 means 300 + 50 + 2

3/3 Numbers in words and figures

In order to put FIGURES into WORDS, we must try to imagine that the number is in a PLACE VALUE table like this one

Hundred	Ten	Unit
1	4	7
One hundred	forty	seven
One hundred and forty-seven		

Hundred	Ten	Unit
4	0	9
Four hundred		nine
Four hundred and nine		

3/3 Compare and order numbers

- Write numbers lining up the digits

Hundred	Ten	Unit
1	4	7
6	3	2
1	7	6
1	6	2

- Begin at the hundreds and compare
632 is the biggest

Hundred	Ten	Unit
1	4	7
6	3	2
1	7	6
1	6	2

- Move to the tens and compare
Order is: 632, 176, 162, 147

3/4 Estimating

- **Eyeball estimate**



Here are 10

Use this to estimate larger quantities



- **Estimate by sampling**

Count your pulse over 15 seconds
Multiply the number of pulses by 4 to get the pulse rate over 1 minute ($15 \times 4 = 60$ seconds)



- **Estimate on a number line**

Fill in the half way number first
Then split up the half with the arrow

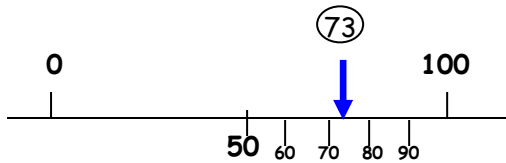
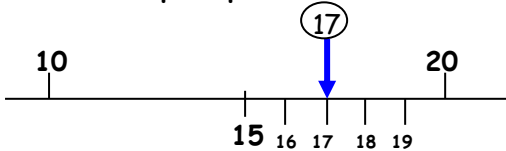

- **Estimate by rounding off a number**

To make a sum easier and give a rough answer

Example: 28 could be rounded to 30
£1.95 could be rounded to £2

3/5 Solve problems by estimating

Example: Estimate the cost of 5 magazines at £1.95 each



Answer: It is about $5 \times £2 = £10$

Example: When full this bottle holds 400ml.
Estimate how much water is left in this bottle.

400ml →



Answer: about 150ml

.....? →

3/6 Add 3 digit numbers mentally

Partitioning

$$236 + 319$$

$$\begin{aligned} & \overbrace{200 + 30 + 6} + \overbrace{300 + 10 + 9} \\ &= 500 + 40 + 15 \\ &= 555 \end{aligned}$$

Subtract 3 digit numbers mentally

$$363 - 126$$

Partitioning

$$\begin{aligned} & \overbrace{363} - \overbrace{100} - \overbrace{20} - \overbrace{6} \\ &= 263 - 20 - 6 \\ &= 243 - 6 \\ &= 237 \end{aligned}$$

Counting on from 126

$$\begin{aligned} & (126) + 4 \\ & \quad 130 + 3 \\ & \quad \quad 133 + 230 \\ & \quad \quad \quad = 363 \\ & \text{Answer} = 237 \end{aligned}$$

1	x	3	=	3
2	x	3	=	6
3	x	3	=	9
4	x	3	=	12
5	x	3	=	15
6	x	3	=	18
7	x	3	=	21
8	x	3	=	24
9	x	3	=	27
10	x	3	=	30
11	x	3	=	33
12	x	3	=	36

3/7 Written method for addition

- Line up the digits in the correct columns

e.g. 132
+ 239
H T U

1	x	4	=	4
2	x	4	=	8
3	x	4	=	12
4	x	4	=	16
5	x	4	=	20
6	x	4	=	24
7	x	4	=	28
8	x	4	=	32
9	x	4	=	36
10	x	4	=	40
11	x	4	=	44
12	x	4	=	48

$$\begin{array}{r} 132 \\ 239 \\ \hline 371 \end{array}$$

Written method for subtraction

- Line up the digits in the correct columns

e.g. 327 - 119

	H	T	U	
	3	2	7	
	1	1	9	-
	2	0	8	

3/8 Estimate answers to calculations

- Round off each number
- Then do the calculation
- Check using the inverse

Example: Estimate 83 - 28

80 - 30 = 50

Inverse: 50 + 30 = 80 ✓

3/9 Missing number problems

Fact family for +/-

$34 + 23 = 57$

$57 - 23 = 34$

$23 + 34 = 57$

$57 - 34 = 23$

3/10 Know the 3, 4 and 8 times tables

Fact family for x/÷

$9 \times 8 = 72$

$72 \div 9 = 8$

$8 \times 9 = 72$

$72 \div 8 = 9$

3/11 Multiply & divide

- A 2-digit number by a single digit

Column method

$$\begin{array}{r} 38 \\ 3 \times \\ \hline 114 \\ 2 \end{array}$$

Grid method

	30	8
3	90	24

$90 + 24 = 114$

Partitioning method

$$\begin{aligned} 38 \times 3 \\ = 30 \times 3 + 8 \times 3 \\ = 90 + 24 \\ = 114 \end{aligned}$$

3/12 Multiply & divide

- Look for connections between two sums
- Remember the fact family for x/÷

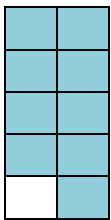
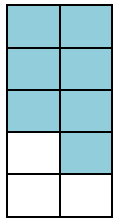
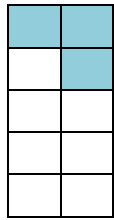
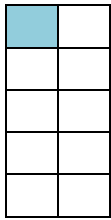

• The same fraction can be expressed in different

$$\frac{1}{10}$$

$$\frac{3}{10}$$

$$\frac{7}{10}$$

$$\frac{9}{10}$$

ways

ALL THESE

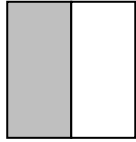

$$\frac{1}{2}$$

=

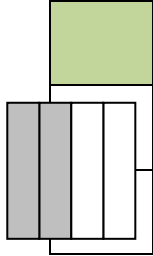

ARE $\frac{1}{2}$

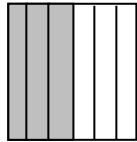

$$\frac{2}{4}$$

=

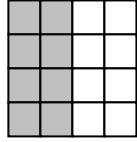

$$\frac{3}{6}$$

=

The bigger the numerator, the bigger the fraction

• Unit Fractions

$$\frac{1}{2}$$

$$\frac{1}{3}$$

$$\frac{1}{6}$$

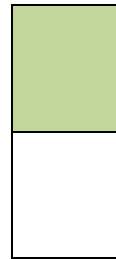

The bigger the denominator, the smaller the fraction

$$\frac{8}{16}$$

ALL THESE ARE $\frac{1}{4}$

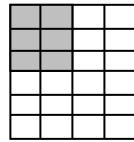
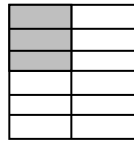
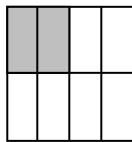
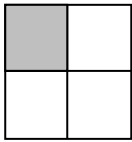

$$\frac{1}{4}$$

=

$$\frac{2}{8}$$

=

$$\frac{3}{12}$$

=

$$\frac{6}{24}$$

3/17 Add & subtract fractions

• To add and subtract fractions

When the denominators are the same

$$\frac{5}{7} + \frac{1}{7} = \frac{6}{7}$$

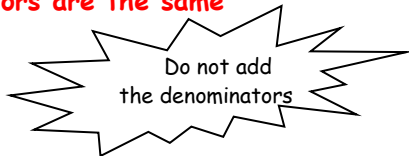

$$\frac{5}{7} - \frac{1}{7} = \frac{4}{7}$$

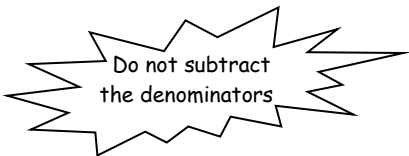

3/19 Add & subtract measures

• The units must be the same

Length - Example

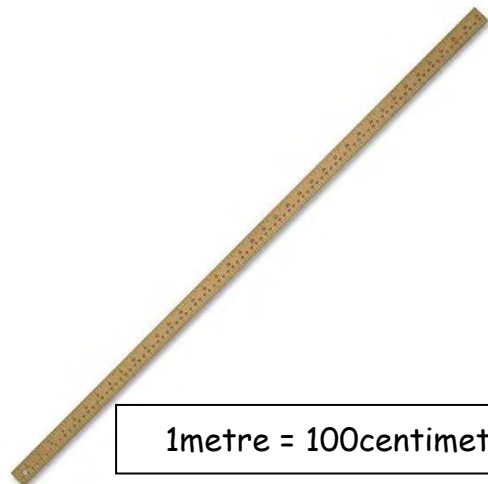

3/18 Compare fractions

• Fractions with the same denominator

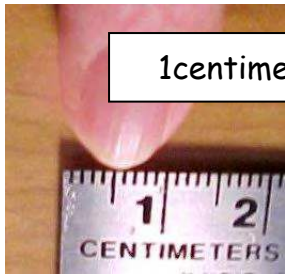

1centimetre = 10millimetres

$$\begin{aligned}
 &3\text{cm} + 7\text{mm} \\
 &= 30\text{mm} + 7\text{mm} \\
 &= 37\text{mm} \\
 &\text{or } 3\text{cm } 7\text{mm or } 3.7\text{cm}
 \end{aligned}$$

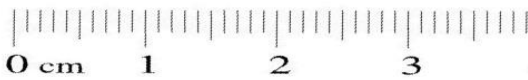
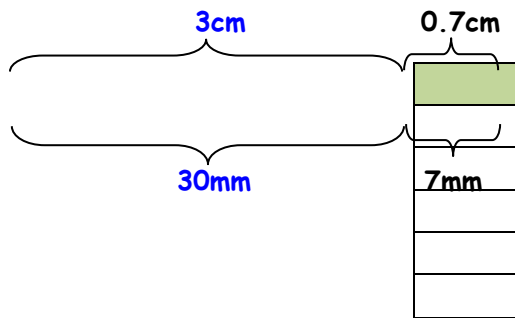

Mass - Example

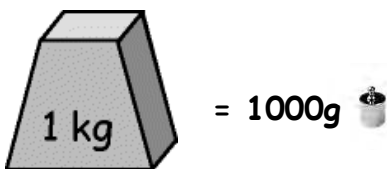

$$\begin{aligned}
 &3\text{kg} - 450\text{g} \\
 &= 3000\text{g} - 450\text{g} \\
 &= 2550\text{g} \\
 &\text{or } 2\text{kg } 550\text{g or } 2.55\text{kg}
 \end{aligned}$$

3/19 Add & subtract measures (continued)

Volume - Example



1litre = 1000millilitres



$$\begin{aligned}
 &800\text{ml} + 720\text{ml} \\
 &= 1520\text{ml} \\
 &= 1 \text{ litre and } 520\text{ml} \\
 &= 1.52 \text{ litres}
 \end{aligned}$$

3/20 Perimeter

PERIMETER is the distance round the outside of a shape

- On a centimetre square grid - count round

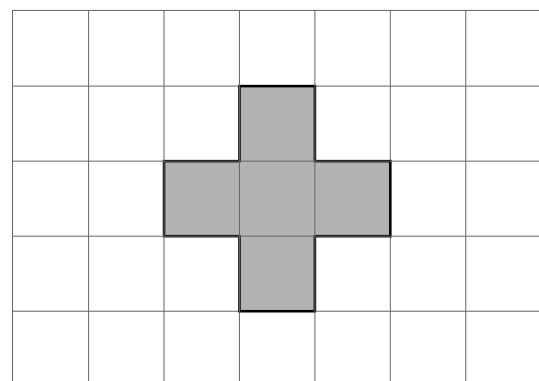

Perimeter of this shape = 12cm

- Measurements given - add up all round



6cm

Perimeter of this shape = $6 + 4 + 6 + 4 = 20\text{cm}$

3/21 Bills and change

To work out a bill

1 chocolate bar - £1.10

1 pen - 10p

1 pencil - 8p

Total = £1.28

To find change by the 'add-on' method

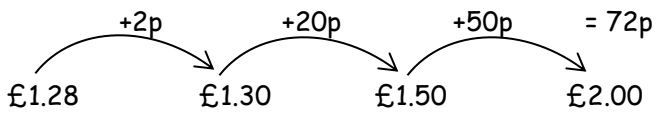

Reading the time

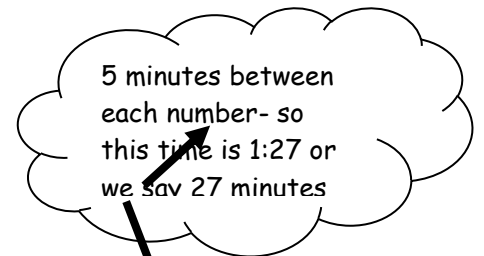
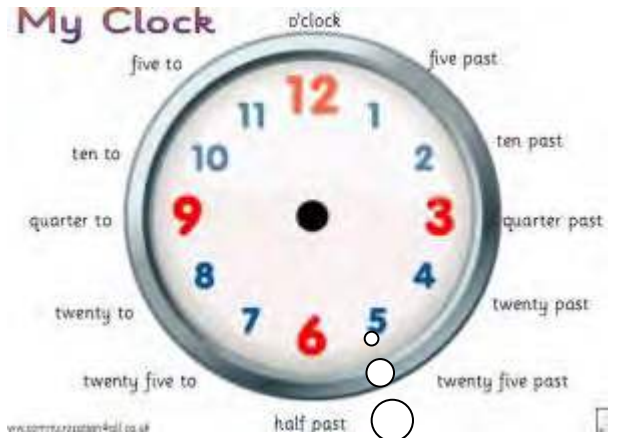

3/22 Time

Analogue clock

Roman

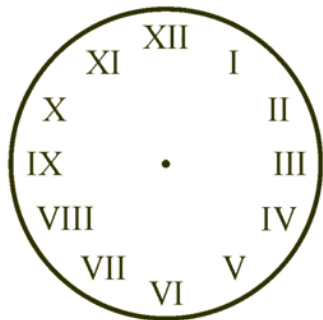

Hindu-Arabic

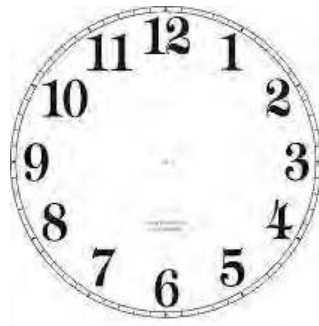

12- and 24-hour clock

Times of the day in 12-hour clock

Morning	Afternoon
12.00 midnight	12.00 noon
1.00 am	1.00 pm
2.00 am	2.00 pm
3.00 am	3.00 pm
4.00 am	4.00 pm
5.00 am	5.00 pm
6.00 am	6.00 pm
7.00 am	7.00 pm
8.00 am	8.00 pm
9.00 am	9.00 pm
10.00 am	10.00 pm
11.00 am	11.00 pm
12.00 noon	12.00 midnight

3/23 Time

3/24 Time - hours minutes, seconds

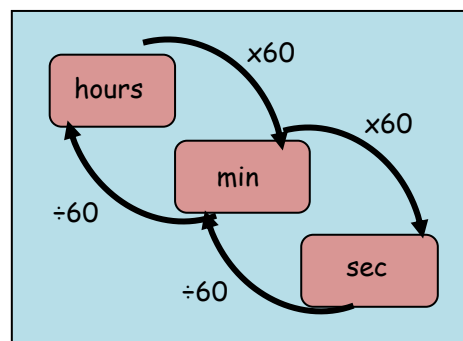

Months of the year

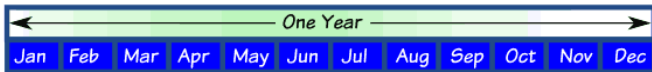

- A rhyme to remember the days in each month

30 days has September,
April, June and November.
All the rest have 31
Except February alone,
Which has 28 days clear
And 29 in each leap year.

- the "knuckle method"



A knuckle is "31 days", and in between each knuckle it isn't.

3/25 - 2D Shapes

- With 3 sides (Triangles)

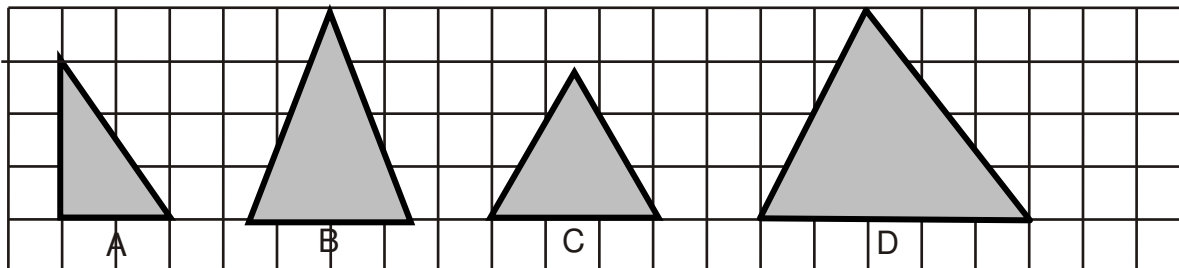

right-angled

isosceles

equilateral

scalene

- With 4 sides (Quadrilaterals)

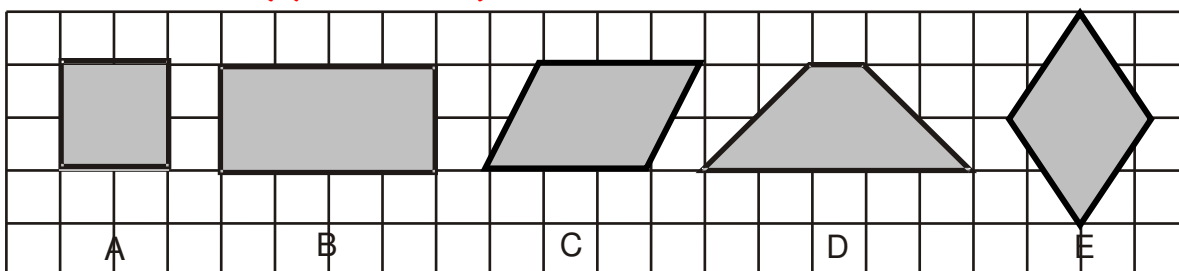

square

rectangle

parallelogram

trapezium

rhombus

- With 5 sides (Pentagons)

- With 6 sides (Hexagons)

And where your hands meet, the two knuckles are "July, August", which both have 31 days.

February has 28 days & 29 days in a leap year (every 4 years)

Days in a year

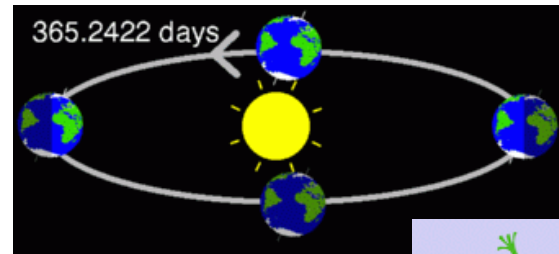

365 days in a year

366 days in a leap year



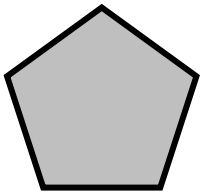

regular

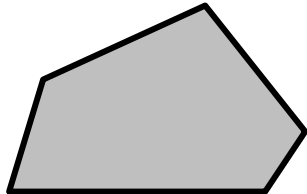

irregular

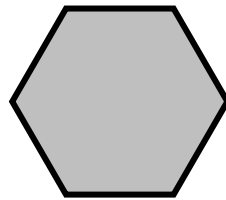

regular

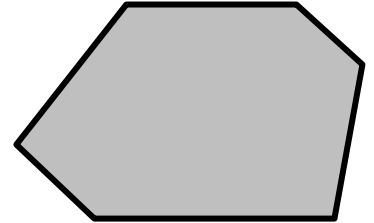

irregular

3/25 - 3D Shapes

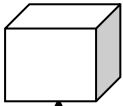

Cube

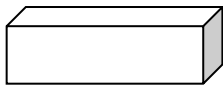

cuboid

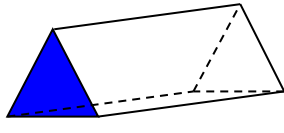

triangular prism

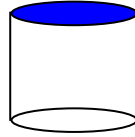

cylinder

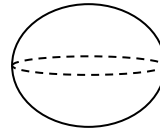

sphere

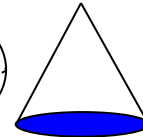

cone

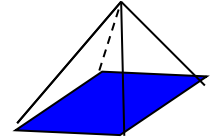

square-based
Pyramid

- Nets

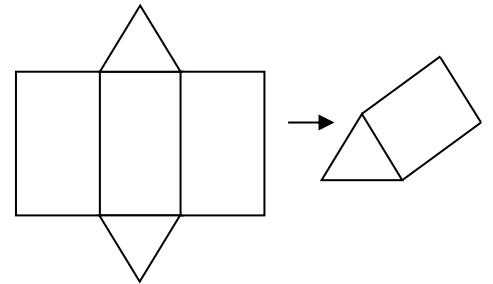
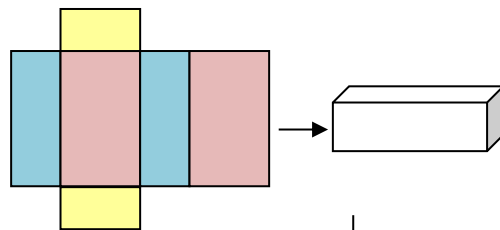
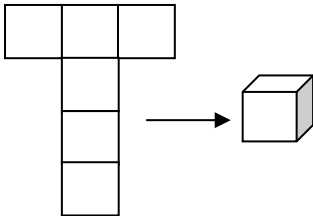

3/26 Angle

- An angle is an amount of turn

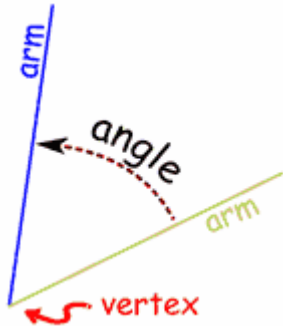

- Angles in shapes

Triangle - 3 angles

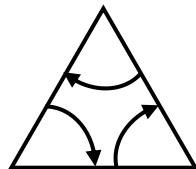

Quadrilateral - 4 angles

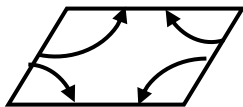

Pentagon - 5 angles

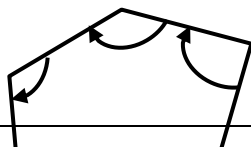

- Names of angles

ACUTE angles are less than 90°

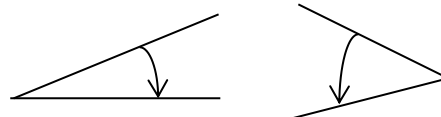

RIGHT angles are exactly 90°

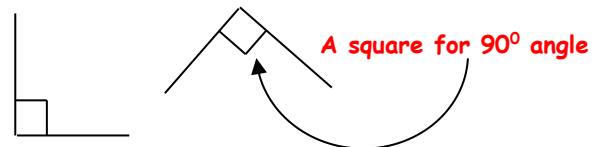

OBTUSE angles are bigger than 90°



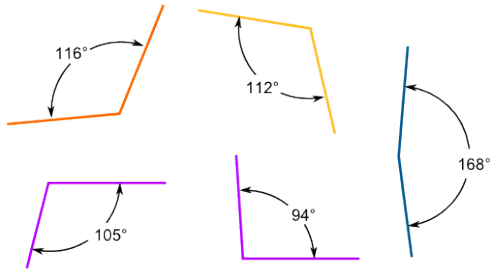

3/27 Right angles

ONE right angle measures exactly 90°

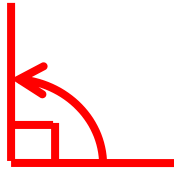

TWO right angles measure exactly 180°
This is called a half-turn

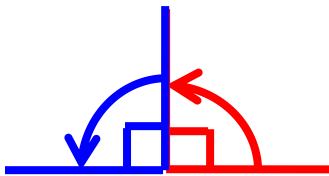

THREE right angles measure exactly 270°
This is called three quarters of a turn

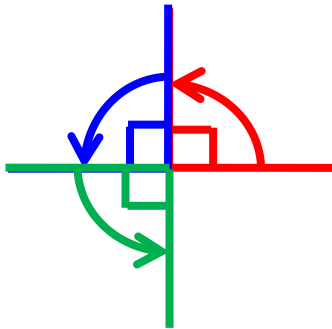

FOUR right angles measure exactly 360°
This is called a full or complete turn

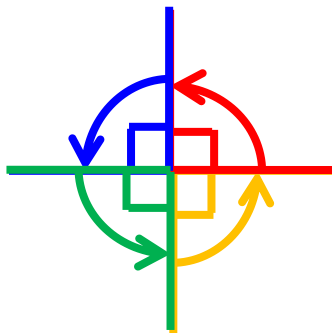

To check if an angle is bigger or smaller than a right angle, use a square corner



↑
This angle is greater than a right angle

↑
This angle is less than a right angle

3/28 Types of Lines



The Horizon is a horizontal line



This cliff face is a vertical line



The running track is parallel lines (never meet)

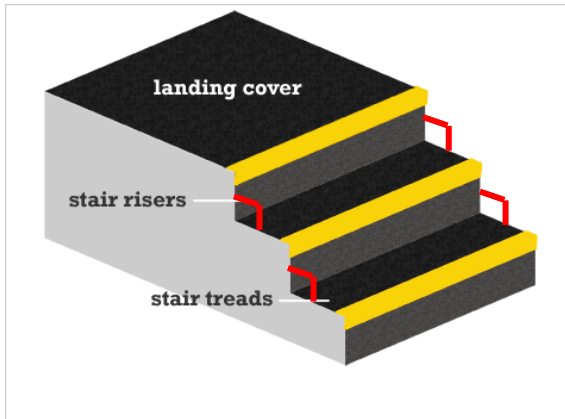

The rise & tread are perpendicular lines (meet at 90°)

3/29 Bar charts

Frequency table to show pets owned by Year 3

A bar graph to show pets owned by Year 3

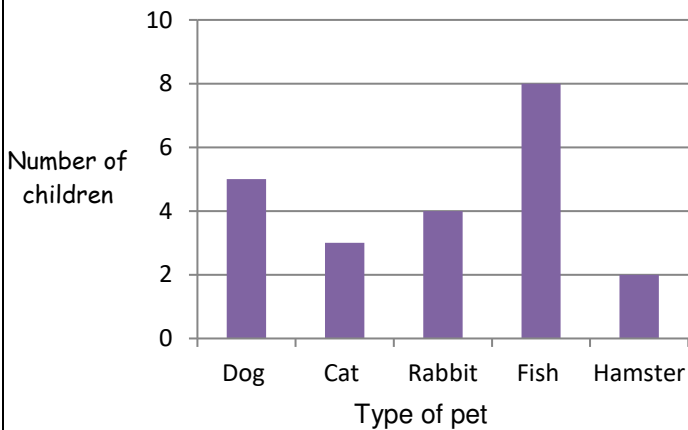

Pictogram to show the colours in a tube of Smarties

Colour	Number of Smarties
Green	
Orange	
Blue	
Pink	
Yellow	
Red	
Purple	
Brown	
Key	= 2 smarties

3/30 Solve answers to questions

• Bar chart in 3/29

- (i) How many more children own a rabbit than a hamster?

Answer: $4 - 2 = 2$

- (ii) What is the difference between the number of children who own a dog and the number of children who own a cat?

Type of pet	Tally	Number of pets
Dog		5
Cat		3
Rabbit		4
Fish		8
Hamster		2

Answer: $5 - 3 = 2$

- (iii) How many pets are owned altogether by the children Year 3?

Answer: $5 + 3 + 4 + 8 + 2 = 22$

• Pictogram in 3/29

- (i) How many fewer blue smarties are there than yellow ones?

Answer: $11 - 5 = 6$

- (ii) Work out the total number of smarties in the tube

Answer: 55

