



GCSE Level Student Resource

OCR Design Engineering Revision and Work Guide – Version 2

Name:

Class:



Contents

Design Cycle

Identify

Design

Optimise

Validate

Human Factors

Anthropometrics and Ergonomics

User Needs

People, Society and Culture

Product Evolution

Market Pull

Technology Push

Iconic Products

Regulations and Standards

Consumer Protection Laws

Copyright, Patents and Trademarks

British and European Standards

Health and Safety

Product Requirements

Function and Features

Limitations and Constraints

Performance

Scales of Production

One-off

Batch

Mass

Continuous

Just-in-time

Manufacturing Considerations

Stock Forms

Standard Components

Durability and Maintenance

Supply Chains

Cost and Budget

Engineering Drawings

Tolerances



Contents

Materials

Plastics

Natural Timbers and Manufactured Boards

Metals

Modelling Materials

Modern and Smart Materials

How to Answer Exam Questions



The Design Cycle

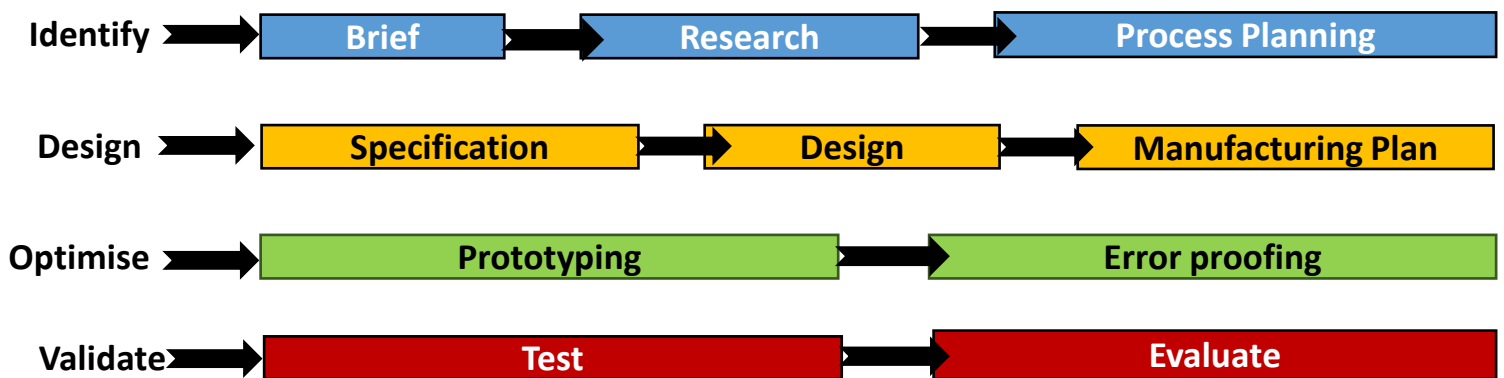
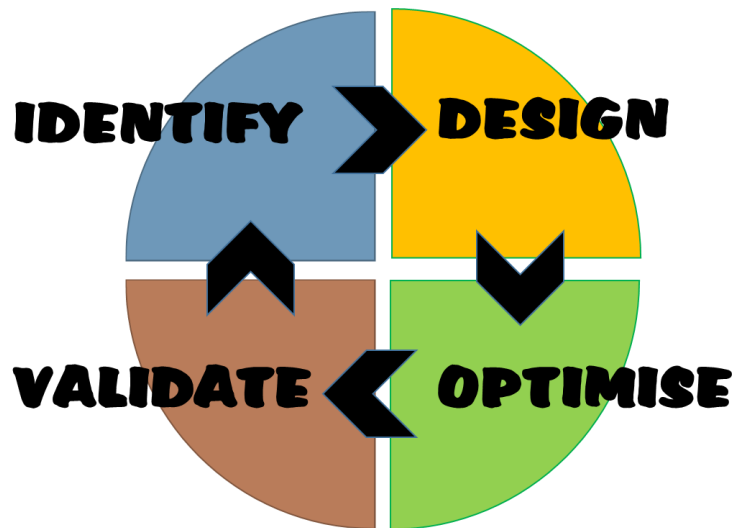

The Design Cycle is the process a Designer goes through to create a product. Once they reach the evaluate stage, designers can return to identify, to correct any issues they found in the testing and evaluation stages.

Designers will also use The Design Cycle as structure to make sure designs are thoroughly developed and reviewed at each stage, and allows the Designers to discuss the design with Client at regular intervals



Activity

- 1) Write a description of what the impact would be if the Identify Stage of the Design Cycle was missing. Explain what benefits there are to the stage.
- 2) Name 2 methods a Designer could use to find out new information
- 3) Why is it useful to use The Design Cycle on existing products?



The Design Cycle - Identify



Designers will often start the design process, with a **Design Problem**, this is something they have to solve.

A **Design Brief** is a *statement of how you are going to solve the Design Problem*.

This will usefully include information you know, and anything unknown is then investigated using research.

Design Briefs will usually include; any limitations or constraints, the Target Market, the product, materials and manufacturing processes.

Example:

The Design Problem:

Tesco have noticed a sudden rise in the number of wireless earbud headphones they are selling to young people.

They have approached you to design a new range of Bluetooth headphones to be released under the Tesco “Own-brand range”



The Design Brief:

I intend to design and make a new range of Tesco “Own-brand” wireless headphones for their young adult customers. They must be Bluetooth and suit the company branding, as well as being appealing to young people.

Once the Brief has been created, areas of research are identified.

A Designer can use various methods in order to find out information, including; interviews, product analysis, market research, reading books, etc

Client feedback is also critical at this stage; their requirements and limitations need to be met in order to create a successful product.

A Client could be another Business (like the Tesco example above) but the User could be the intended Target Market (like the young adult demographic in the example above)



The Design Cycle - Identify



Research findings and Client feedback can be used to create a **Process Plan**.

This plan will often include a production budget, timeline, and what processes, materials and components will be required to successfully create the final product.



Activity

1) Briefly describe what happens in the Identify stage of the Design Cycle

2) What is the difference between a Client and a User?

3) Write a Design Brief for the Design Problem below, and then identify what areas of research would need to be carried out before the Design Stage.

“Sony have found that their elderly customers struggle to use their remotes, as they find them complicated to use and difficult to hold. Sony need a designer to create a new remote, that is compatible with their products, that their older target market can use.”



Past Paper Question – Summer 2016 Paper

1 The design cycle is a process used by many designers to help them create new products.

(a) (i) Complete the table below by adding the missing phases of the design cycle in the correct order.

Phase 1 has been completed for you.

| | optimise phase | design phase | validate phase |
|---------|----------------|--------------|----------------|
| Phase 1 | identify phase | | |
| Phase 2 | | | |
| Phase 3 | | | |
| Phase 4 | | | |

[3]

(ii) Complete the statement below.

During the identify phase of the design cycle, designers will firstly discuss and create a design with the client. They will then carry out to assess the needs of the user.

[2]



The Design Cycle - Design



A **Design Specification** is a *list of requirements your product has to meet in order to be successful*.

This list of requirements has been developed from analysing research findings, and gives the Designer criteria to meet when designing.

This specification is also useful when evaluating the final product

Example:

| Specification Points | Meaning |
|----------------------|--|
| Aesthetics | What the product will look like, style, colour, etc |
| Customer | Who the Target Market is, how it will appeal to them, what Anthropometrics and Ergonomics will be used, etc |
| Cost | Cost to make, as well as cost to sell |
| Environment | Where it will be used |
| Safety | How it will be safe to use, what standards and regulations it will have to meet |
| Size | What dimensions it will be, as well as components and parts |
| Function | What the purpose of the product will be, and what Features it will have |
| Materials | What is will be made from |
| Manufacture | How it will be be made |

Once the Specification has been developed, the designing of the product will begin.

Often a team will work together, not just of designers, but of different branches of a company e.g. lawyers, advertisers, manufactures, accountants, so that all of the aspects of the business are considered.

This will help with starting points and mind mapping ideas and directions.

Different considerations will also be taken into account, including; Anthropometrics, Ergonomics, Features, Competitiveness, etc



The Design Cycle - Design



A Designer (and their team) will firstly create **Free-Hand Sketches** to quickly get ideas down onto paper.

These ideas are often in large quantities, and once a few are selected, those are then developed further and looked at in more detail.

A Final Design is then created. This is often detailed and can be refined on a piece of **CAD software (Computer Aided Design)**, like Autodesk or Photoshop.

Once this design has been approved by the team, team leader and Client, it is then developed into an Engineering Drawing

Engineering Drawings are to show the manufacturers the precise measurements and parts of the full product. There can be multiple Engineering Drawings for a product if it is very complicated.

Once the final design has been chosen, a Manufacturing Plan is then created.

This sets out all the information about the stages of production. Including; Preparation, Processing, Assembly, Finishing and Packaging.

This Manufacturing Plan will also include, the timeline, budget, material sources and preparation, as well as manufacturing processes, sizes and **Standard Components**

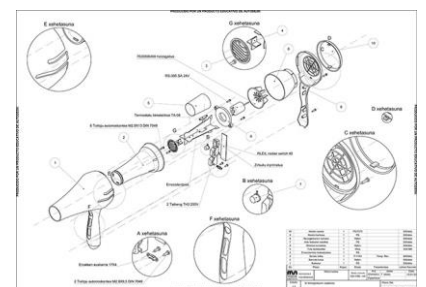
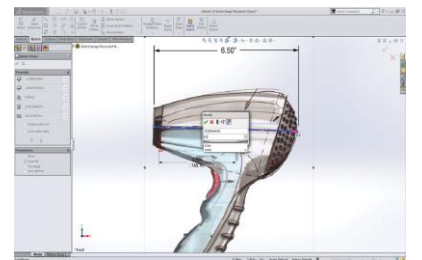
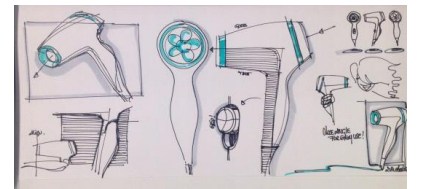
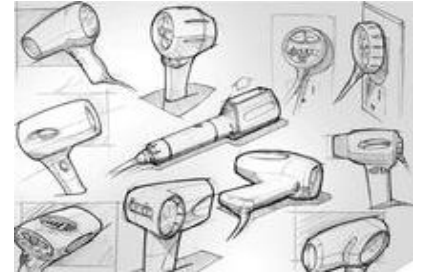

Activity

1) Give 2 potential specification points for a pen

2) Why would a Designer ask for Client Feedback after creating the Final Design?



The Design Cycle - Optimise



Prototyping is the creation of a **model or “mock-up”** of a product after the Design Process

For example, Dyson famously made 5,127 prototypes before releasing his first vacuum cleaner!



Prototyping is useful because it can check if the materials and manufacturing processes would be suitable/available for the product.

You can also gain customer/ client feedback on the product, as well as comparing the product to the Design brief and specification to see if it meets the requirements it needs to in order to be successful.

If the prototype shows any issues, this allows the designer to change the designs.

Prototypes can be made using modelling materials, as well as 3D CAD Software

Error Proofing is ensuring that the product cannot be assembled or used in an incorrect way (helpful to both manufacturers as well as customers)

This can be done by ensuring parts as are few as possible, parts can only be put together a certain way and giving clear indications/ instructions for parts



A good example of Error Proofing is the sockets on the back of a TV or side of a computer. The sockets are often colour coded and labelled to match the cables, and the cables/ components can only be put in a certain way that works.

They can't be used incorrectly.



Activity

- 1) Why is it useful to prototype out of modelling materials rather than the materials that would've been used for the product?
- 2) Give 2 advantages of CAD modelling over modelling with physical materials
- 3) Give an example of a product that uses Error Proofing in its design



The Design Cycle - Validate



There are numerous ways of testing a product. Including:

- Weight/dimension checks
- Chemical Checks
- Visual Checks
- Destructive Testing/ Strength Testing
- User Group Testing
- Temperature Testing
- Operational/Function Testing

- Client Evaluation
- Product Analysis/Comparison



Which?

Sometimes Companies, won't just test and evaluate products themselves – they'll also get independent groups to it, like **Which?**

This is also reassuring for customers, as they can read unbiased reviews of products and compare between multiple companies

Testing and Evaluation happens because designers need to ensure the product is successful before being released, and is competitive with the market.

They must also ensure it is safe to use, meeting standards and legal requirements, as law suits and potential criminal charges would be severe if a customer was harmed using their product.

Also, any other imperfections can be identified and The Design Cycle can be repeated in order to improve the product

Activity

1) Give 1 activity carried out during the Validate Stage of The Design Cycle

2) Give 2 ways a Designer could test a car and why those tests would be useful

3) What are the potential consequences of releasing products that haven't been tested and evaluated?



Human Factors

Anthropometrics is the *study of measurements of the human body*

Ergonomics is the *application of anthropometrics in order to make products and places efficient, comfortable and safe to use*

Anthropometric Data will be used for different genders, ages and even nationalities. This is applied to products in order to make them suitable to use.

Ergonomics is the application of that data, and often products are **adjustable** in order to be **inclusive**. A car interior is a perfect example of adjustability to suit a variety of people.

A remote control is also a good example of Ergonomics at work

The placement of buttons on a remote is important to make sure they're easy to reach and big enough to press

Remotes often have silicone grips and buttons which are soft and comfortable.



User Groups are specific groups of people who need products to be adjusted for their needs. For example, the Elderly, Visual Difficulties, Physical Disabilities and Mental Disabilities.



The needs and requirements of these groups has to be considered and research thoroughly before a product can be made for them.



Activity

- 1) Sketch and annotate a design of a kettle that has been adjusted for a someone with Visual Difficulties
- 2) List as many things that are adjustable in the interior of a car
- 3) What anthropometric measurements would need to be considered when creating a par of headphones



Human Factors

When designing a product, designers and manufacturers need to be aware of people, society and cultural influences that will affect their products.

Different groups of people have different interests and have to be catered for, as well as different countries will react differently to different products/ brands.

E.g. In Japan white is worn for funerals, whereas in the UK we wear black

E.g. In India McDonalds don't sell beef burgers as it has a large Hindu population, and cows are seen as sacred – in contrast the UK sells its most amount of fish and chips on a Friday as it is a Christian tradition to not eat meat on that day.



Past Paper Example – Summer 2015 Paper (Worth 6 marks)

(c)* Discuss the effect of cultural and fashion trends on the aesthetic design of new products.

Guidance

Examples and relevant points could include:

Global trade means that companies / manufacturers carrying out business across the world must understand that aesthetics are interpreted in different ways in different cultures. Aesthetics acceptable in one country may be seen as unacceptable in another. When designing a product or its packaging designers often produce a variety of designs to match the preferences of different countries.

AESTHETICS - Colour, Shape and Form

The shape and form of the product may determine the look of a product. Products are often designed to look stylish. The style applied to the outside of a product can quite easily influence the technology inside it. Aesthetics can also alter the production / manufacturing techniques through which it is made.

CULTURE – Values and Beliefs

Some products are aimed at different cultures and countries. A product acceptable in one culture may be looked as offensive or less desirable in another. The use of colours and colour schemes are a good example of this.

e.g

- Importance of colour schemes in different countries is linked to the success or failure of a product.
- In China black is associated with evil, dirt, sin, disasters and bad luck.
- In general, in China, colours are characterised by their lightness or darkness. For instance, white is regarded as a pure colour and reflects honesty. Red is associated with good luck. Elsewhere in the world red is used to represent danger.

Guidance

One example of cultural influence would be the Shell Petrol sign, developed for use initially in California, which at the time had a very much Hispanic culture, so Phillip Lowie considered pure red and bright yellow colours appropriate. So successful was the final colour choice that it was copied many times by other companies (for example the McDonald's logo colours).

As a result of European interest in Japanese culture and beliefs in the early 1900's, the influence of the rising sun, geometric shapes, circles and straight lines and block colours were manifest in many of the iconic designs of Art Deco, particularly ceramics and decorative items.

Earlier, in the 18th century, with extensive trade with China, there developed a now typically English preoccupation with the drinking of tea. The British ceramic industry flourished with the popularity of making and drinking tea.

Even the Georgian furniture makers began an affair with everything Chinese: Chippendale, for example, created many chair and room screen designs based on interlaced geometric patterns in wood.

More recently, because of the global success of Japanese electronic products, the influence of Japanese culture has had an impact in logo design and font design. Many forward looking UK companies have adopted the sleek, space age, often incomplete letter style for their trademarks and brand symbols inspired by Japanese origins.

To gain top marks in this answer you need to include: Multiple well-explained points, specialise terms, good range of examples and accurate spelling, punctuation and grammar



Product Evolution

Product Evolution is when products **change and develop** in reaction to different factors, including:

- Technology Push
- Market Pull
- Culture
- Fashion/ Trends
- Competition from other companies
- Manufacturing Techniques

Products can change over a period of months, years or even decades. With each version of itself, supposedly, better than the last.

Technology Push is when *new developments in materials and technologies improve existing products/ create new ones*

Market Pull is when **consumers demand improvements/new products. Often found by conducting market research**



Game Controllers are a fairly modern product, but have radically changed due to; advancements (and availability) of materials and electronics, customer feedback and greater understanding of ergonomics.

Controllers buttons have become more accessible for players to reach, and even have been adapted to different shapes e.g. guitars and steering wheels for a more realist gaming experience

Control pads and buttons have been made from different materials to make them more **ergonomic**, and the electronics inside have become smaller allowing the controllers to be made a lighter weight and smaller size. Electronic advancement has also allowed for wireless controllers, removing potential tripping hazards and improving movability.



Activity

1) Give 3 examples of products that have developed over time

2) Choose one of the products you have listed and explain how it has changed and why those changes happened

3) What is the difference between Technology Push and Market Pull?



Product Evolution

Iconic Products are designs/products that set a new bench mark for others to follow.

- It is a ground breaking design, in terms of its technology or manufacturing techniques.
- It is a design that stands the test of time, remaining popular despite the passing of years.
- It is often recognised immediately by consumers.
- It is often emulated/copied by other designers.



Angle poise Lamp



Apple iPod



Lego



Swiss Army Knife

The above products (among others) changed the industry with their innovative designs. For example; The iPod's new technology was ground-breaking at the time and became very popular with consumers, and other companies mimicked the design to try and access that target market. The Dyson vacuum is also an iconic product as it removed issues found in previous vacuums e.g. vacuum bags, poor suction, etc and made vacuuming more convenient for consumers. The aesthetic of these products also made them popular, and often become "timeless" and copied by other designers.

Past Paper Question – Summer 2017 Paper

10

6 Designers may take inspiration from iconic products.

(a) (i) Give **one** example of an iconic product.

..... [1]

(ii) State **two** reasons why the product you have chosen became iconic.

1

.....

2

.....

[2]



Regulations and Standards

Consumer protection laws and legislation are what a rights a consumer has to be protected against defective products, and what companies have to follow to have products sold in different countries. All companies must abide by these laws or face legal consequences.

| | |
|--|---|
| Sales and Supply of Goods Act 1994 | All Products have to be of a “satisfactory quality. They have to be safe, fit intended purpose, not be faulty |
| Trade Descriptions Act | False or misleading information must not be given out about products. E.g. accurate information must be given out who made the product |
| Consumer Protection Act 1987 | The right to claim compensation if a defective product causes death, damage or injury |
| The Waste Electrical and Electronic Equipment Regulations 2013 | The government regulate the amount of electronics going to landfill as the chemicals and electronics can harm the environment and wildlife Companies must provide electronic disposal for their products |

What’s the difference between copyright, patent and trademark?

Copyright is the protection of literary and artistic works such as books, videos, music, etc



A Registered design protects the appearance of a product e.g. shape and aesthetic. This can be renewed every 5 years up to a total of 25 years protection



A Trademark protects a brand definition/ identity such as logos, slogans, etc



A Patents protects an intention or process, and stops other companies copying the way something works. This can renewed after 4 years annually.

Past Paper Question – Summer 2016 Paper

(e) Explain why companies would apply for a patent when creating a new product.

.....

.....

.....

..... [2]





Regulations and Standards

Standards are often set by countries, to ensure all products are safe to use. The most common are:



British Standards Kitemark shows that a product has consistently met the requirements of the British Standards Institute. These regulations are of a higher standards than European ones



European Conformity Symbol shows that a product has consistently met the minimum requirements of the EU

| SITE SAFETY | | | |
|-------------|--|--|---|
| | Construction work in progress Parents are advised to warn children of the dangers of entering this site | | Danger Demolition work in progress |
| | No admittance for unauthorised personnel | | Use ear protectors |
| | This is a hard hat area | | High visibility jackets must be worn |
| | Protective footwear must be worn | | Warning Look out for overhead loads |

| SAFETY PRACTICES | | | | | |
|------------------|----------------|--|----------------------|--|-------------|
| | Flammable | | Harmful / Irritant | | Corrosive |
| | Poison / Toxic | | Explosion | | Biohazard |
| | Oxidizer | | Environmental Hazard | | Radioactive |

Health and safety considerations are important, not just for consumers using products, but the manufacturers making them as well.

Often symbols are used around workshop areas, as well as being on products to ensure people are being safe in an area/ using equipment or a product

Activity

- 1) Why are symbols used rather than written words?
- 2) Which is more difficult to pass – British or European standards? Why?
- 3) What does Copyright do?
- 4) Why do consumer protection laws exist?



Product Requirements

Product requirements are what a product has to meet/ must do.
Common requirements are:

- Function – *what a product's purpose/ job is*
- Features – *what makes a product unique and sellable*
- Performance – *how well it completes its function*
- Target Market – *how it appeals to its customers*
- Working Environment – *how it is suitable for where it will be used*
- Constraints – *what it must do or must not do*
- Aesthetics – *what it will look like*
- Ergonomics – *how its comfortable and safe to use*
- Lifecycle – *what environmental impact it makes (and how that can be reduced)*

Example:

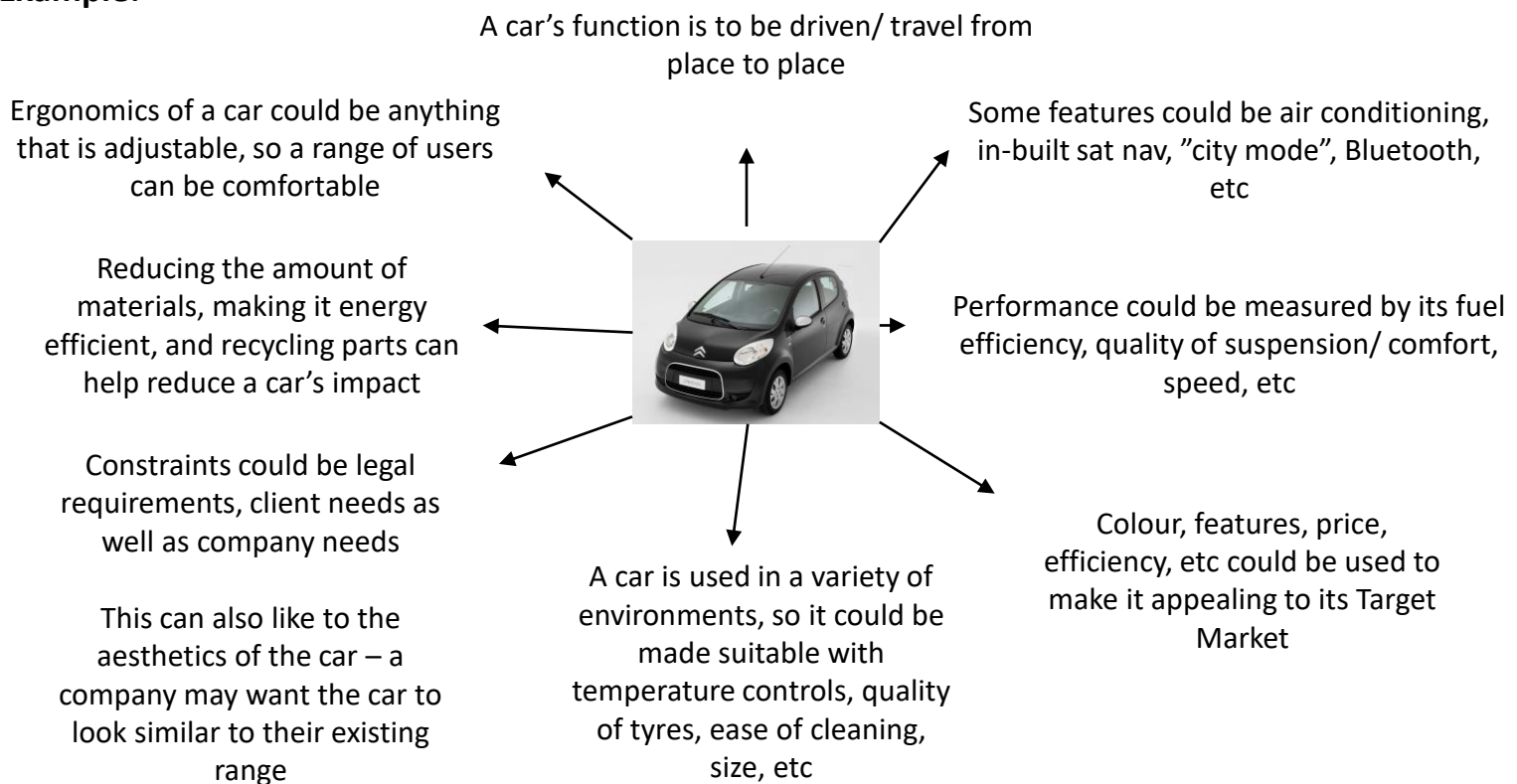

Activity

- 1) Like the example of the car above, do a mind map of the product requirements of a laptop
- 2) Compare and contrast these requirements for the laptop, with a desktop computer – what are the similarities? The differences?
- 3) What would be the changes made, to a personal laptop to make it suitable to be a work/ business laptop? Explain why these changes might be made



Scales of Production



One-off Production

This is the manufacture of **one item**

This item can be custom made/ designed (bespoke manufacture)

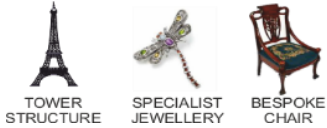

TOWER STRUCTURE

SPECIALIST JEWELLERY

BESPOKE CHAIR

How can you tell it's one-off production?

- Specialised companies/ items
- Specialist materials
- High quality items
- Skilled workers
- Expensive

Batch Production

This is where small quantities of identical items are made (10s-1000s)

To ensure all items are identical, jigs, moulds and templates to aid workers

How can we tell it's batch production?

- Small quantities of products
- Mix of workers and automatic machinery
- "Stations" of workers, creating and assembling the products



SPECIAL EDITION CAR

KNOCKDOWN FURNITURE



Mass Production (High-Volume Production)

This is where large quantities of products are made (10,000s-100,000s)

There are often assembly lines (for the main product) and sub-assembly (for small pieces and components)

How can we tell when it's mass production?

- Heavily automated
- Large product output
- Standardised/ identical products





Scales of Production

Continuous Production

This is when large quantities of products is produced (100,000s +)

However, unlike Mass Production this is **never ending** production e.g. power plants

How can we tell when it's continuous production?

- Heavily automated
- Large product output
- Standardised/ identical
- "Never ending" production



Just-in-time production (JIT)



This is when products made to order, but can be used in conjunction with any other scale of production

There is no need for warehouse space, as materials/ parts are ordered when needed.

However, if timings are wrong/ orders are delayed there is a big financial impact

Activity

1) Give 3 examples of products made using each scale of production

2) Why would availability of materials be important to Mass Production?

3) Why is one-off production expensive?

4) If you were to make a limited edition product, what scale of production would you use and why?



Manufacturing Considerations

When manufacturing a product, there are several considerations that need to be planned for. These considerations often include:

- Standard Components
- Stock Forms
- Supply Chains
- Durability and Maintenance
- Product Safety
- Costs and Budget



A **standard component** is usually an individual part or component, manufactured in thousands or millions, to the same specification. These are often bought in bulk and saves companies money, rather than them trying to make their own. The sizes of standard components are often internationally recognised, making manufacturing easier to communicate

Examples of standard components would be; nuts, bolts, hinges, panel pins and screws, etc

A **stock form** is when a raw material has been machines/processed into a stock/standard size, shape or form. This can be easily used during manufacturing on a production line.

Like standard components, buying in these stock forms is often easier and cheaper than companies trying to create their own and are internationally recognised



Supply Chains are the process a product goes through, from sourcing the materials to being distributed to the consumer

Examples of stock forms would be; sheet of aluminum, acrylic rod, pine dowel, sheet of MDF, etc



Supply chains are effected by many things, including:

- Smaller/less equipped factories would impact the amount of products you could make
- Availability/ cost of materials
- Amount of warehouse storage/ budget to buy/rent warehouse space
- Size of distribution team would effect how many products and distance of product travel



Manufacturing Considerations

Product safety is a key consideration of any designer. Products can be made to be safe, in a variety of ways. Including;

- Consistently passed testing and standards (British and European)
- Non-toxic finishes and materials
- Suitable for the market (age appropriate, etc)
- Error Proofing
- Suitable warnings and instructions



Products not being safe can result in a range of consequences, which designers obviously want to avoid! There could be public product recalls, which as well as being expensive to do can cause a poor reputation to customers. There could also be law suits which can result in fines and even criminal charges.

How **Durable** something is, is how long that product/ material can last. Generally the more durable something is the better!

Customers and manufacturers are more likely to buy a durable product than one that isn't going to last. So often designers will make products that are as durable as possible

Products can be made more durable when they are maintained. This can be done by:

- Repairing
- Replacing parts (disassembly)
- Not over-using a product/ using it in correctly
- Storing and caring for a product correctly

However, there is something called **Planned Obsolescence**. This is where products are supposed to “die” after a certain period of time

This can be for loads of different reasons, including; profit, not able to make a product last an extended period, etc

Examples include: light bulbs, disposable cutlery, printer ink, phones, etc

Activity

- 1) Give as many examples as you can, for ways that a car can be maintained
- 2) What is the difference between a standard component and a stock form?
- 3) Why would a company's reputation be important to their business?



Engineering Drawings

Engineering drawings, are technical drawings, that show how to make a product. An engineering drawing will always contain specific measurements, detailed drawings and **tolerances**.

Tolerances are the allowances for products/parts/materials to not meet their exact sizing

E.g. If a product's diameter is 5mm, the tolerance might be 4.9mm – 5.1mm

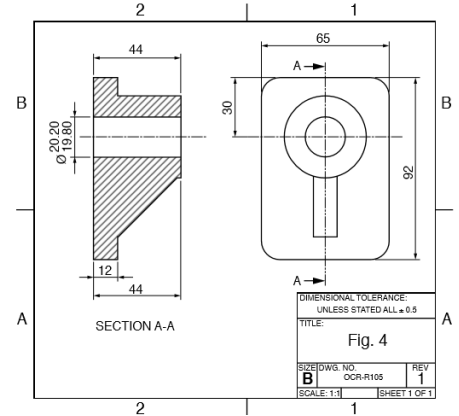

Tolerances exist because it is extremely difficult to get the exact measurement every time, and not allowing any variation can result in a high amount of waste. However, a product/part must still function within tolerance.

\varnothing = Diameter

\pm = Tolerance is (though doesn't appear on all drawings)

Example:

| | | |
|--------------------|-------------|--|
| \varnothing 10mm | \pm 0.2mm | = Would mean that the tolerance is: 9.8mm – 10.2mm |
|--------------------|-------------|--|

Activity

1) On the image on the top left, circle where the tolerance is shown in the drawing

2) What would the tolerance be for the equations below?

$$\varnothing 10\text{mm} \quad \pm 0.4\text{mm}$$

$$\varnothing 53\text{mm} \quad \pm 0.1\text{mm}$$

3) Why do we use tolerances?



The Environment

The 6 Rs

| Word | Meaning |
|---------|--|
| Reuse | Using a product again, for either the same or a different purpose |
| Reduce | Not using as much materials/ parts in products and packaging |
| Refuse | Not buying or using non-environmentally friendly products |
| Recycle | Reprocessing used materials to make new products |
| Rethink | Considering better materials, manufacturing processes and ways to make products, that make less of an environmental impact |
| Repair | Fixing a product rather than throwing it away |

Designing for Disassembly is when products are made to be taken apart. This can be useful for repairing products, like cars, as the broken part can be taken out and replaced with a new one.

This is also useful for recycling products, as the different parts can be sent to specific recycling centres rather than being thrown away as a whole.

Some examples of making a product suitable for disassembly, would be to use temporary fixings (screws, etc), using components that can be removed using common tools and keeping materials separate so they can be easily recycled.

Renewable resources are materials that can be re-grown/ re-bred, so we don't run out

Examples include:

- Woods
- Paper
- Cotton
- Leather

Non-renewable resources include plastics and metals

Sustainable resources are ones that can be maintained over time e.g. trees can be re-planted and re-grown after being cut down

Sustainable resources are meant to have as little impact on the environment as possible

Designers can ensure their designs are sustainable by:

- Choosing sustainable materials
- Giving appropriate disposal (recycling) instructions
- Manufacturing products in less of an impactful way



The Environment

Resource Depletion is when resources are being used at a faster pace than they can be replaced. This then means there is no more of that natural resource left. Resource depletion can happen to both renewable and non-renewable resources.

Product Lifecycle is what environmental impact a product makes over its life time. Including:

- Impact of materials
- Impact of processes
- Product Miles (how far a product has to travel to get from factory to consumer)
- Impact while in use
- Impact when disposed of (6Rs)

A Lifecycle Analysis is when a designer looks at a product's impact and considers what can be improved to minimise its impact.

Past Paper Example – Winter 2015 Paper (Worth 6 marks)

(c)* Discuss how a company can present a more responsible image to customers by carrying out Life Cycle Analysis (LCA) of their products.

Examples and relevant points could include:

Materials:

- Improved use of materials/ technologies/recyclable
- Using sustainable materials
- More sustainable materials may be chosen, instead of the cheapest

Design:

- Sustainable design means less waste from new materials and more use of recyclable components.
- Sustainable design may lead to production efficiency, less pollution

Production:

- Time taken to prototype a product can be reduced by advances in modelling, production processes, and use of CAD modelling techniques
- Use of improved production processes and new technologies to enable improved product features and functions, using technology in manufacture.
- Lower waste, saving costs of waste management

Energy:

- More sustainable sources of energy could give the company a lower carbon footprint
- Cleaner/alternative production processes will mean health environmental benefits to workers and community

PR







- Consumers may pay more for sustainably designed products
- Manufacturer seeking alternatives to non-renewable materials, finding other sustainable materials give good public image
- Using sustainable methods is good PR for companies which produce products

To gain top marks in this answer you need to include: Multiple well-explained points, specialise terms, good range of examples and accurate spelling, punctuation and grammar



The Environment

Symbols are often used to help communicate with manufacturers and customers about the environmental impact of products

| Symbol | Name of Symbol | Purpose of Symbol |
|---|-----------------------------------|--|
|  | Recycling Symbol | The product/ materials the product is made from can be recycled |
|  | Forest Stewardship Council Symbol | The materials used for aren't harming the world's rainforests. They are meeting high environmental and social standards. |
|  | The Green Dot | Used in Europe to show the manufacturer has made a financial contribution to recycling packaging in Europe |
|  | Tidyman Symbol | Encourages users to dispose of waste correctly |
|  | Recycling Code | To indicate the material used can be recycled |
|  | EU Directive | This helps show consumers how energy efficient a product is |
|  | Encouraging Electronics Recycling | Shows some products/ chemicals can't be put in the bin and need to be disposed of a certain way |



Activity

- 1) Draw the Tidyman symbol
- 2) What is resource depletion?
- 3) Name 3 renewable energy sources and name 2 non-renewable energy sources
- 4) Give examples of how the 6rs can be used in real-life e.g. reducing packaging on Easter eggs



Materials

Thermoplastics: Plastics that can be reheated and reshaped an infinite amount of times

Thermosetting plastics: Plastics that once heated and shaped can't be remoulded. They are permanently shaped and are incredibly heat resistant.

Thermoplastics

| Common Name | Properties | Common Uses |
|----------------------------------|--|--|
| ABS | High impact strength, lightweight and durable | Phone cases, helmets and toys |
| Acrylic | Food-safe, tough and durable | Car lights and illuminated signs |
| PP | Lightweight, food-safe and good chemical resistance | Food containers and medical equipment |
| HIPS (High Impact Polystyrene) | Good impact resistance, lightweight and stiff | Toys and fridge linings |
| LDPE (Low density Polyethylene) | Lightweight, low rigidity and good chemical resistance | Carrier bags, detergent bottles and toys |
| HDPE (High density Polyethylene) | Stiff and good chemical resistance | Crates, buckets and bowls |

Thermosetting Plastics

| Common Name | Properties | Common Uses |
|-----------------------|---|--|
| Epoxy Resin | High strength and good chemical and wear resistance | Adhesives and surface coatings |
| Urea Formaldehyde | Rigid, hard, brittle and good insulator | Electrical fittings and adhesives |
| Melamine Formaldehyde | Rigid, strong and scratch resistant | Tableware and decorative laminates for work surfaces |

Natural Timber: Woods that are naturally grown i.e. from trees

Softwoods: Woods that have come from a Coniferous Trees. These trees are Evergreen and don't loose their leaves/ keep growing in Winter.

Hardwoods: Woods that come from Deciduous Trees. Loose their leaves and stop growing in winter. Start growing and produce fruit/flowers in Spring.

Man-Made Boards: Manufactured using woods and adhesives. They are not natural.



Materials

Manufactured Boards

| Common Name | Properties | Common Uses |
|---------------------------------|---|------------------------------------|
| Plywood | Very strong, durable and won't warp | Furniture |
| MDF (Medium Density Fibreboard) | Smooth and even surface, easy to machine and often veneered | Patterns for Casting and furniture |
| Chipboard | Available in a range of densities and has a relatively even surface | Furniture and flooring |

Hardwoods

| Common Name | Properties | Common Uses |
|-------------|---|--|
| Oak | Strong, hard but easy to work with | High quality furniture, veneers and roof beams |
| Mahogany | Strong, durable and hard. Very aesthetically pleasing | Indoor furniture, Veneers, Worktops and flooring |
| Teak | Durable, oily and resistant to moisture | Outdoor furniture and boats |

Softwoods

| Common Name | Properties | Common Uses |
|-------------|--|---|
| Pine | Light in colour, inexpensive, often contains knots and easy to machine | DIY, school projects and simple joinery |
| Spruce | Soft texture and fairly lightweight | Musical instruments |

Ferrous Metal: Contain Iron and are magnetic and can rust.

Non-Ferrous Metal: Do Not contain Iron, are not magnetic and tarnish

Alloys: A mixture of 2 or more metals in order to gain the best of their properties



Materials

Ferrous

| Common Name | Properties | Common Uses |
|-----------------|---|--|
| Mild Steel | Ductile, malleable and rusts quickly when exposed to moisture | Nuts, Bolts and car bodies |
| Tool Steel | Strong and hard | Hand Tools and springs |
| Stainless Steel | An alloy with chromium and nickel, doesn't rust and easy to sterilise | Kitchen utensils, surgical instruments and teapots |

Non-Ferrous Metals

| Common Name | Properties | Common Uses |
|-------------|--|--|
| Aluminium | Lightweight, can be polished and malleable | Cooking foil, saucepans and chocolate wrappers |
| Copper | Can turn green after being exposed to moisture, good conductor and malleable | Plumbing and electrical components |
| Tin | Ductile and malleable and resistant to corrosion | Coating on food cans and packaging |

Modelling Materials are ones that are commonly used to model and make prototypes with. Common modelling materials include:

- Paper
- Card
- Blue Foam
- Clay
- Polystyrene
- MDF
- Polymorph

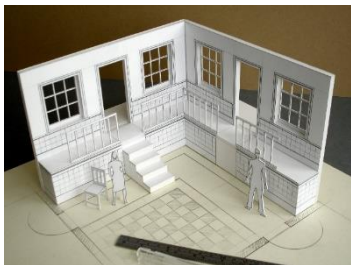



Materials

New/ modern materials are materials that **have been recently developed**.

Examples of Modern Materials include:

- **Titanium** – Good strength to weight ratio, non-corrosive and can be mixed with other metals to gain further properties. Applications include; medical prostheses, aircraft and dental implants.
- **Kevlar** – Good strength to weight ration, withstand high-impacts, and can be woven into clothing. Applications include; body amour, racing sails and tyres
- **Carbon Fibre** – Very high strength to weight ratio, and can be moulded into a variety of shapes. Applications include; bicycle frames, F1 cars, and sporting equipment

Smart Materials are materials that **change in reaction to the environment**. They may react to moisture, heat and UV rays, for example.

Examples of Smart Materials include:

- **Thermochromic Pigments** – This is when the pigments change colour in reaction to heat. Applications of this include; baby bottles, hair dye and mugs
- **Photochromic Pigments** – This is when the pigments change colour and/or opacity in reaction to light. Applications of this include; Signage and smart glass
- **Shape Memory Alloys** – This is when alloys, no matter how they are bent and manipulated, return to their original shape. They are also non-corrosive and are resistant to moisture. Applications include braces and glasses



Activity

1) Why is Kevlar suitable for body armor?

2) Name 2 materials that would be suitable for food packaging

3) Why don't designers make their prototypes out of their intended materials – why do they use specific modelling ones?

4) What is the difference between a modern and smart material?

How to Answer Exam Questions

1 Mark Questions – Identify/name/label

2 Mark Questions – Identify and explain/ define



Past Paper Question – Winter 2018 Paper

(b) (i) Draw the symbol for the 'European Conformity' mark below. . [1]

(ii) State two other examples of symbols that may be included on a product.

1

.....

2

.....

[2]

3 Mark Questions – Identify, explain and give an example



Past Paper Question – Winter 2018 Paper

(d) Explain the difference between a registered design and a patent.

.....

.....

.....

.....

.....

.....

[3]

How to Answer Exam Questions

4 mark Questions – Often Identify/ label 4 items

5 mark Questions – Often Identify/ label 5 items



Past Paper Question – Winter 2018 Paper

4 The table below shows a range of different products and the material they are made from.

(a) Complete the table below by adding the most appropriate function:

Lightweight and strong







Non-toxic and easy to mould

Forged and hardened to resist wear

Impact resistant and transparent

Hygienic and resistant to corrosion

One has been done for you.

| | Product | Material | Function |
|---|---|------------------|------------------------------------|
| 1 |  Formula 1 Front Wing | Carbon fibre | |
| 2 |  Engine Crankshaft | Cast alloy steel | |
| 3 |  Motorcycle Helmet Visor | Polycarbonate | |
| 4 |  Building Blocks | ABS | |
| 5 |  High-performance Bicycle Brake Lever | Aluminium billet | Lightweight metal, easy to machine |
| 6 |  Cutlery | Stainless steel | |

