

1. Year Groups
Year
3/4

2. Aspect of D&T
Electrical systems
Focus
Simple programming and control

4. What could children design, make and evaluate?
illuminated sign noise-making toy vehicle
nightlight display lighting
other – specify

5. Intended users
themselves younger children older children
teenagers parents shoppers friends
school general public other – specify

6. Purpose of products
hobbies and interests utility pleasure
advertising comfort illumination
other – specify

16. Possible resources
microcontroller or a standalone control box or an interface box
collection of battery-powered, manually-controlled and programmable electrical products

17. Key vocabulary
series circuit, fault, connection, toggle switch, push-to-make switch, push-to-break switch, battery, battery holder, light emitting diode (LED), bulb, bulb holder, USB cable, wire, insulator, conductor, crocodile clip

7. Links to topics and themes
Homes Travel and Holidays Cities
Emergency Vehicles School Business
Enterprise Light and Dark other – specify

8. Possible contexts
home school leisure culture shops
enterprise environment sustainability
local community other – specify

9. Project title
Design, make and evaluate a _____ (product) for _____ (user) for _____ (purpose)
To be completed by the teacher. Use the project title to set the scene for children's learning prior to activities in 10, 12 and 14.

different switches including toggle, push-to-make, push-to-break
plastic packaging, card, corrugated plastic, reclaimed materials, finishing media
output devices including buzzers, bulbs, bulb holders, LEDs, zinc carbon or zinc chloride batteries, battery holders, wire, automatic wire strippers right/left handed scissors, PVA glue, cutting mats

control, program, system, input device, output device, process
user, purpose, function, prototype, design criteria, innovative, appealing, design brief

3. Key learning in design and technology

Prior learning

- Constructed a simple series electrical circuit, using bulbs, batteries, switches and buzzers.
- Cut and joined a variety of construction materials, such as wood, card, plastic, reclaimed materials and glue.

Designing

- Gather information about users' needs and wants, and develop design criteria to inform the design of products that are fit for purpose.
- Generate, develop, model and communicate realistic ideas through discussion and, as appropriate, annotated sketches, cross-sectional and exploded diagrams.

Making

- Order the main stages of making.
- Select from and use tools and equipment to cut, shape, join and finish with some accuracy.
- Connect simple electrical components and a battery in a series circuit to achieve a functional outcome.
- Program a standalone control box, microcontroller or interface box to enhance the way the product works.

Evaluating

- Investigate and analyse a range of existing battery-powered products, including pre-programmed and programmable products.
- Evaluate their ideas and products against their own design criteria and identify the strengths and areas for improvement in their work.

Technical knowledge and understanding

- Understand and use computing to program and control products containing electrical systems, such as series circuits incorporating switches, bulbs and buzzers.
- Know and use technical vocabulary relevant to the project.

10. Investigative and Evaluative Activities (IEAs)

- Discuss, investigate and, where practical and safe, disassemble different examples of relevant battery-powered products, including some programmable and programmed commercially available products e.g. *Where and why the products are used? How do they work? What are the key features and components? How does the switch work? Is the product manually controlled or controlled by a computer? If it is controlled by a computer how does that improve the way the product works? What materials have been used and why? How is it suited to its intended user and purpose?*
- Ask children to investigate examples of switches, including those which are commercially available, which work in different ways e.g. push-to-make, push-to-break, toggle switch. Let the children use them in simple circuits e.g. *How might different types of switches be useful in different types of products? How might different output devices be used?*
- Remind children about the dangers of mains electricity.



11. Related learning in other subjects

- **Science** – know how to construct simple series circuits and have a basic understanding of conductors, insulators and open and closed switches.
- **Spoken language** – participate in discussion and evaluation of battery-powered, programmable products. Ask relevant questions to extend knowledge and understanding. Build their technical vocabulary.

12. Focused Tasks (FTs)

- Recap with the children how to make manually controlled, simple series circuits with batteries and different types of switches, bulbs, motors and buzzers. Discuss which of the components in the circuit are input devices e.g. switches, and which are output devices e.g. bulbs, motors and buzzers.
- Demonstrate how to find a fault in a simple circuit and correct it, giving pupils opportunities to practise.
- Demonstrate and ask children to practise the use of a simple computer control program using an interface box, microcontroller or standalone control box to control output devices, e.g. bulbs and buzzers, using a repeating sequence of instructions.
- Ask the children to make a variety of switches by using simple classroom materials e.g. card, corrugated plastic, aluminium foil, paper fasteners and paper clips. Encourage children to make switches that operate in different ways e.g. when you press them, when you turn them, when you push them from side to side. Ask the children to test their switches in a simple series circuit.
- Teach children how to avoid making short circuits.



13. Related learning in other subjects

- **Science** – know how to construct simple series circuits and have a basic understanding of conductors, insulators and open and closed switches.
- **Computing** – design, write and debug programs that accomplish specific goals, including controlling physical systems.
- **Spoken language** – asking questions to check understanding, develop technical vocabulary and build knowledge.

14. Design, Make and Evaluate Assignment (DMEA)

- Develop a design brief with the children within a context which is authentic and meaningful.
- Discuss with children the purpose of the battery-powered, programmable products that they will be designing and making and how they will work more effectively for the intended user than those that are manually controlled. Consider who they will be for and how they address a problem or need.
- Ask the children to generate a range of ideas, encouraging realistic responses. Agree on design criteria that can be used to guide the development and evaluation of the children's products, including safety features.
- Using annotated sketches, cross-sectional and exploded diagrams, as appropriate, ask the children to develop, model and communicate their ideas.
- Ask the children to consider the main stages in making and testing before assembling high quality products, drawing on the knowledge, understanding and skills learnt through IEAs and FTs.
- Have the children write, test and debug programs that will control the electrical product they have made for a clearly defined purpose e.g. bulb on a nightlight switching off after a period of time when the user has gone to sleep or LEDs flashing on and off to illuminate a sign in a shop window.
- Evaluate throughout and the final products against the intended purpose and, where safe and practical, with the intended user, drawing on the design criteria previously agreed.



15. Related learning in other subjects

- **Spoken language** – maintain attention and participate actively in collaborative conversations, staying on topic and initiating and responding to comments. Develop understanding through speculating, hypothesising, imagining and exploring ideas.
- **Science** – know how to construct simple series circuits and have a basic understanding of conductors, insulators and open and closed switches.
- **Computing** – design, write and debug programs that accomplish specific goals, including controlling physical systems.
- **Art and design** – using and developing drawing skills.

18. Key competencies

problem-solving teamwork negotiation
consumer awareness organisation motivation
persuasion leadership perseverance
other – specify

19. Health and safety

Pupils should be taught to work safely, using tools, equipment, materials, components and techniques appropriate to the task. Risk assessments should be carried out prior to undertaking this project.

20. Overall potential of project

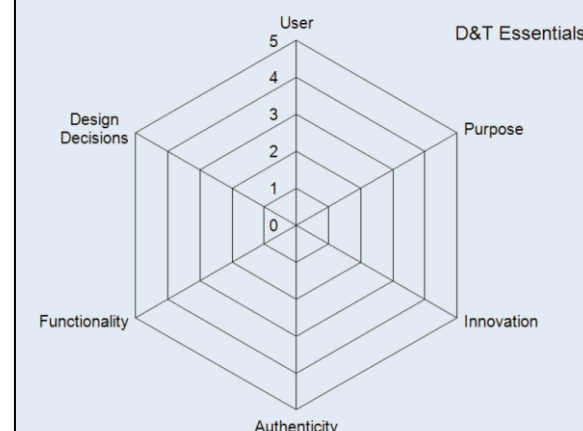

Instant CPD

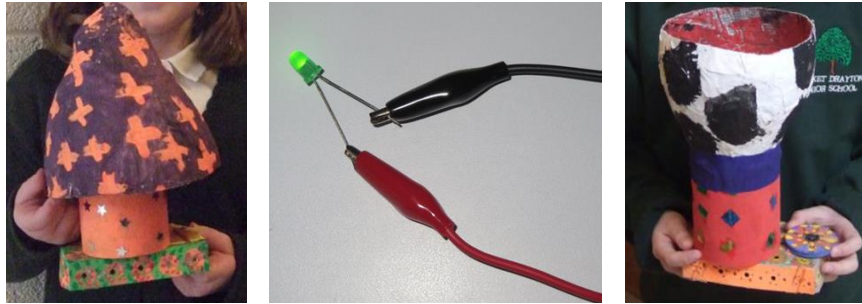

Tips for teachers

- ✓ Please also refer to the Instant CPD guidance in 'Year 3/4 Electrical systems – simple circuits and switches' when carrying out this project.
- ✓ Clean plastic drinks bottles or clear plastic packaging can be used to make housings for nightlights.
- ✓ Do this project around the same time or just after electricity is covered in science lessons.
- ✓ Build up a collection of battery-powered manual and programmable products, such as nightlights, for children to investigate and evaluate.
- ✓ Crocodile clips can be difficult for small fingers to manipulate. Stress the need for making secure connections.
- ✓ Set up a 'working' circuit so that children can test suspect components.
- ✓ Some components (e.g. buzzers and LEDs) need to be connected the right way round in a circuit, ensuring positive and negative match the poles of the interface box (e.g. FlowGo) or microcontroller (e.g. Crumble).
- ✓ Light emitting diodes (LEDs) with internal resistors should be used.
- ✓ Use 1.5v AA zinc carbon or zinc chloride batteries.
- ✓ Do not use alkaline, lithium or rechargeable batteries.
- ✓ Use Crumble-friendly battery boxes with a built-in resettable fuse to protect against short circuits.
- ✓ Teach children how to avoid making short circuits.
- ✓ CLEAPS recommend zinc carbon and zinc chloride batteries for Primary schools, not rechargeable, lithium or alkaline as these can overheat if short circuited. Button batteries are not recommended for younger children.

Useful resources at www.data.org.uk

- [Crumble kit suitable for KS2 and related guidance](#)
- [Primary Subject Leaders' File Sections 5.8 and 5.10](#)
- [Applying Computing in D&T at KS2 and KS3](#)
- [Torches, Lamps and Lanterns](#)
- [Developing Handmade Switches](#)
- [Night lights \(links to Literacy\)](#)
- [Handmade Switches Helpsheet](#)

Connecting up a Crumble and an example program

This arrangement is for a nightlight or an illuminated sign that flashes on and off, using a light emitting diode (LED) as the output device.

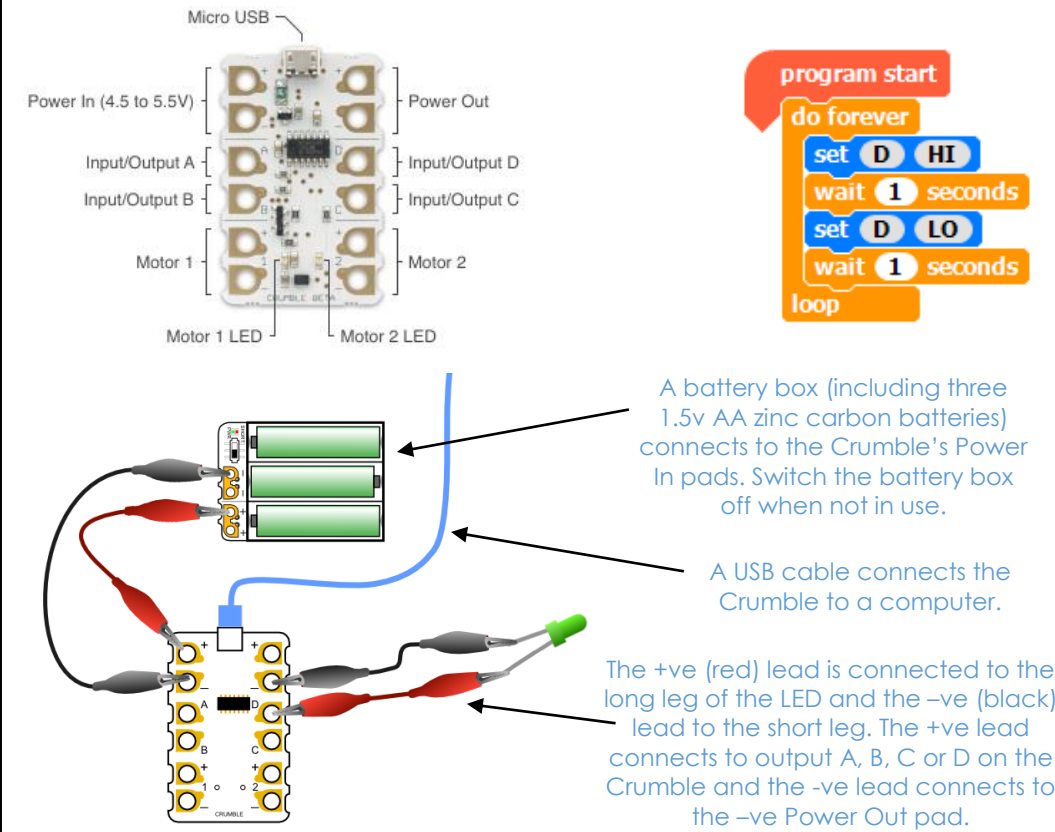

Simple programming and control

Crumble drag and drop interface and menus

Click the green arrow to start the program.

Once the Crumble has been programmed, it will remember the program and run it automatically when the USB cable is disconnected.

Dragging blocks from the interface allows them to snap into place.

You might alter the nightlight program by including a time limit for the light to shine after it is turned on.

Control boxes and program ideas

An alternative to the Crumble or similar microcontrollers is a simple standalone control box or an interface box. Interface boxes sometimes use programming software in the form of flowcharts. Instructions and example programs can be easily found on the internet and adapted for use in products that children wish to design and make.



Designing, making and evaluating a personalised, programmable nightlight for themselves or another child

An iterative process is the relationship between a pupil's ideas and how they are communicated and clarified through activity. This is an example of how the iterative design and make process *might* be experienced by an individual pupil during this project:

| THOUGHT | ACTION |
|---|--|
| What sort of nightlight shall I make and who will it be for? What parts will it have? How will it appeal to the user? | Discussing ideas, drawing annotated sketches, cross-sectional and exploded diagrams, generating design criteria. |
| How will I control my night light so that it turns on and off when I want it to? How will it be powered? | Discussing ideas, modelling possible electrical circuits and programs. |
| What will I use as a housing to contain the parts of the product? | Discussing, exploring and trialling materials. |
| Who will I work with? How long will it take? What order will I work in? Which solution works best? | Negotiating, developing and agreeing a plan of action. |
| How shall I decorate it to make it appealing to a child/myself? | More actions... trialling, testing and modifying the program and design. |
| More thoughts ... appraising, reflecting, refining. | Discussing, exploring and trialling possible solutions and options. |
| Will the nightlight meet the needs of the user and achieve its purpose? | Evaluating the nightlight with the intended user, where safe and practical, and against design criteria. |

Glossary

- **Program** – a sequence of instructions that can be used to control electrical components.
- **Microcontroller** – a device that can be programmed to control how an electrical product operates.
- **Light emitting diode (LED)** – an output device that glows when electricity is passed through it.
- **System** – a set of related parts or components that together achieve a desired outcome.
- **Output devices** – components that produce an outcome e.g. bulbs, motors and buzzers.
- **Input devices** – components that are used to control an electrical circuit e.g. switches.
- **Process** – how a computer program controls one or more output devices.